

Product Specification

(Common Application)

Product Name: VGM084084A0F01

Product Code: M02200

Customer
Approved by Customer
Approved Date:

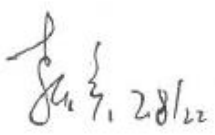
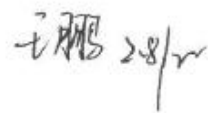
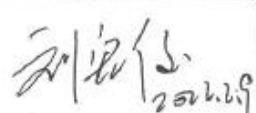
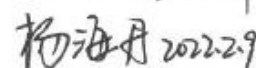
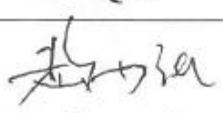
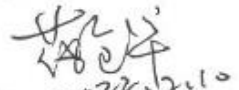
Designed By	Checked By	Approved By	
		R&D	QA
 2022.2.28	 2022.2.28	 2022.2.29  2022.2.29	  2022.2.28

CONTENT

REVISION RECORD	3
1 APPLICATION FILED	4
2 OVERVIEW	4
3 FEATURES.....	4
4 MECHANICAL DATA	4
5 MECHANICAL DRAWING	5
6 MODULE INTERFACE.....	6
7 FUNCTION BLOCK DIAGRAM	7
8 ABSOLUTE MAXIMUM RATINGS.....	8
9 ELECTRICAL CHARACTERISTICS	9
9.1 DC ELECTRICAL CHARACTERISTICS	9
9.2 ELECTRO-OPTICAL CHARACTERISTICS	10
9.3 AC ELECTRICAL CHARACTERISTICS	11
10 FUNCTIONAL SPECIFICATION AND APPLICATION CIRCUIT	13
10.1 POWER ON AND POWER OFF SEQUENCE.....	13
10.2 APPLICATION CIRCUIT.....	15
10.3 DISPLAY CONTROL INSTRUCTION.....	17
10.4 RECOMMENDED SOFTWARE INITIALIZATION	17
11 PACKAGE SPECIFICATION.....	19
12 RELIABILITY	20
12.1 RELIABILITY TEST.....	20
12.2 LIFETIME.....	20
12.3 FAILURE CHECK STANDARD	20
13 ILLUSTRATION OF OLED PRODUCT NAME	21
14 OUTGOING QUALITY CONTROL SPECIFICATIONS.....	22
14.1 SAMPLING METHOD	22
14.2 INSPECTION CONDITIONS	22
14.3 QUALITY ASSURANCE ZONES.....	22
14.4 INSPECTION STANDARD.....	23
15 PRECAUTIONS FOR OPERATION AND STORAGE.....	26
15.1 PRECAUTIONS FOR OPERATION	26
15.2 SOLDERING	26
15.3 PRECAUTIONS FOR STORAGE.....	26
15.4 WARRANTY PERIOD.....	26

1 Application filed

Common Application

2 Overview

VGM084084A0F01 is a full color OLED display module with 84(RGB)×84 dot matrix. The characteristics of this display module are high brightness, self-emission, high contrast ratio, slim/thin outline, wide viewing angle, wide temperature range, and low power consumption.

3 Features

- Display Color: Full Color
- Dot Matrix:84(RGB)×84
- Driver IC: LD7138
- Interface: Serial
- Wide range of operating temperature: -40°C to 70°C
- Wide range of Storage temperature: -40°C to 85°C

4 Mechanical Data

NO.	ITEM	SPECIFICATION	UNIT
1	Dot Matrix	84(W)×84(H)	-
2	Dot Size	0.1319(W)×0.1271(H)	mm ²
3	Dot Pitch	0.1569(W)×0.1451(H)	mm ²
4	Aperture Rate	45.7	%
5	Active Area	13.155(W)×12.17(H)	mm ²
6	Panel Size	18.02(W)×18.5(H) ×1.00(T)	mm ³
7	Module Size	18.02(W)×28.8(H) ×1.16(T)	mm ³
8	Diagonal A/A Size	0.71	inch
9	Module Weight	0.78±10%	gram

5 Mechanical Drawing

如本印章非红色, 则表明该文件为非受控版本, 不会受到控制和更新. 请使用受控文件.
受控章
分发号:

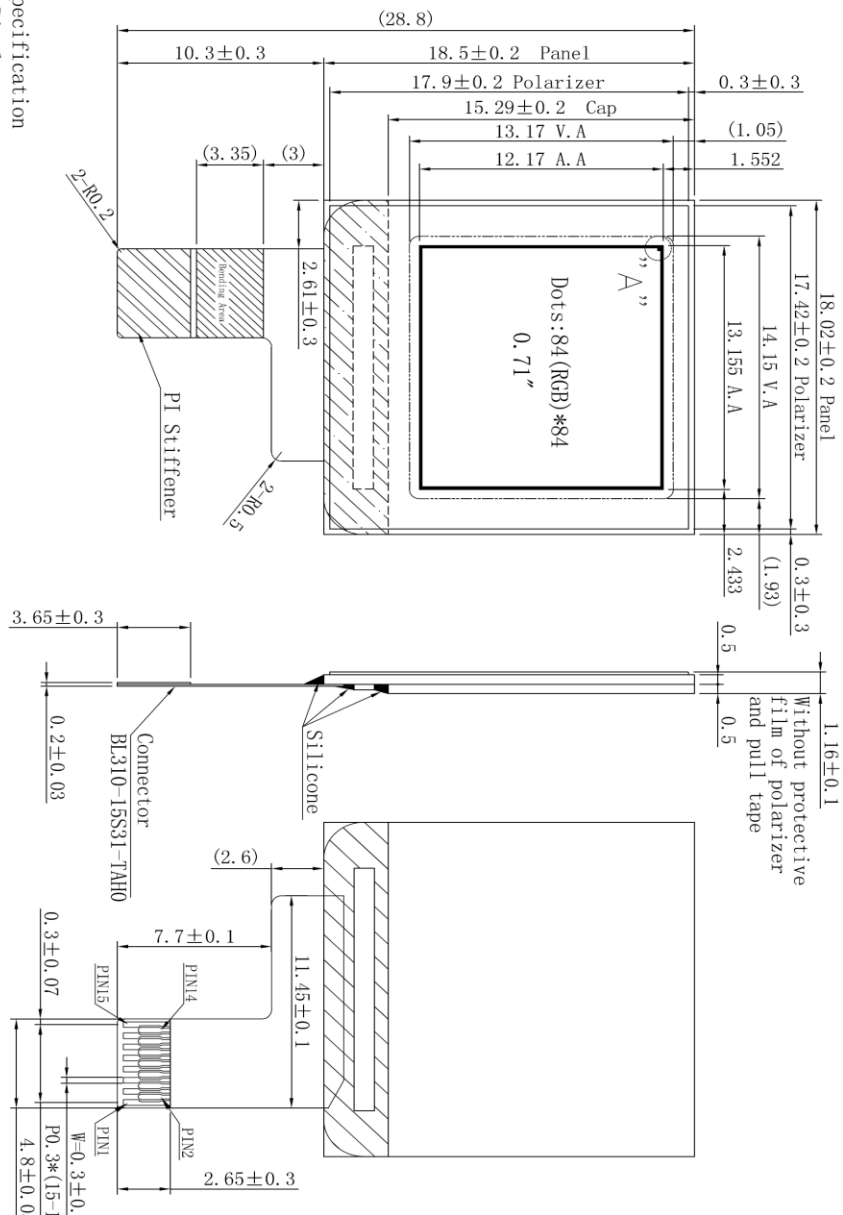

- Specification
1. Display: OLED(Full color)
 2. Format: 84(RGB)*84
 3. Driver IC: LD7138
 4. General Tolerance: ±0.3
 5. Operate temp: -40°C ~ 70°C
 6. Storage temp: -40°C ~ 85°C
 7. DUTY: 1/84
 7. HSF Compliant

Customer Approval		Module Ass'y		Date	Rev.	Unit	Sheet
Signature		2017.10.25		01	mm	1/1	
Part Name	Project Code	DES' D BY	CHK' D BY	CHK' D BY	APPROVED		
Part No.	02200	02200-MA1-A					

Rev.	Date	Note
1	2017.10.25	Primary

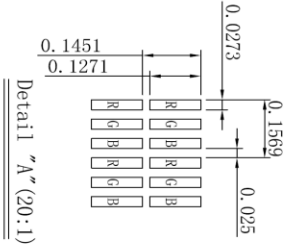
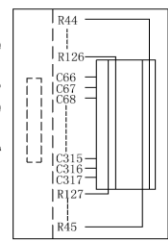

Pin Assignment NO.	SYMBOL
1	VCC C
2	AGND
3	VDDL
4	VDD
5	PSEL
6	RSTB
7	GND
8	CSB
9	DC
10	SCL
11	SDIN
12	GND
13	AGND
14	VCC C
15	VCC R

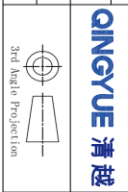

6 Module Interface

PIN NO.	PIN NAME	DESCRIPTION
1	VCC_C	Column Driver Power.
2	AGND	Analog (Driver) GND.
3	VDDL	Internal Logic Power. Refer to application guide. Capacitor is connected between VDDL and VSSD.
4	VDD	Interface Power & Analog Power.
5	PSEL	This pin enable/disable internal logic power regulator. When this pin is tied with VDD pin, it is the internal logic power regulator enabled.
6	RSTB	Reset (Active Low).
7	GND	Ground.
8	CSB	Chip Select (Active Low).
9	DC	Address (L: command, H: Parameter).
10	SCL	serial clock input.
11	SDIN	serial data input.
12	GND	Ground.
13	AGND	Analog (Driver) GND.
14	VCC_C	Column Driver Power.
15	VCC_R	This pin is the power output pin of internal row power regulator. A 4.7uF capacitor is recommended to connect between VCC_R and GND.

7 Function Block Diagram

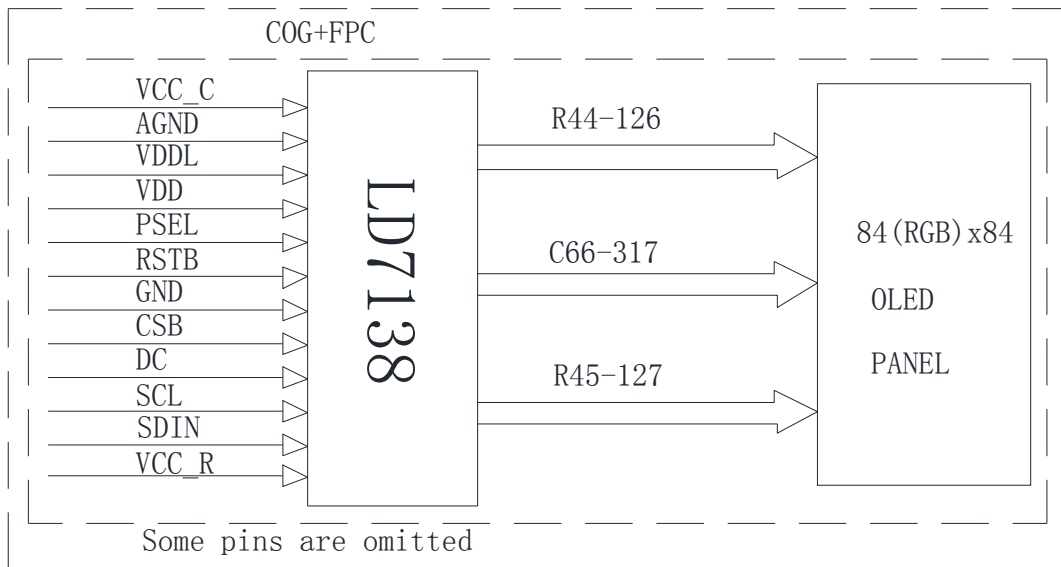

8 Absolute Maximum Ratings

ITEM	SYMBOL	MIN	MAX	UNIT	REMARK
Supply Voltage	VDD	-0.3	+3.6	V	IC maximum rating
	VDDL	-0.3	+2.4	V	IC maximum rating
	VCC_C	-0.3	+20.0	V	IC maximum rating
Operating Temp.	Top	-40	70	°C	-
Storage Temp	Tstg	-40	85	°C	-

Note (1): All of the voltages are on the basis of “VSS = 0V”.

Note (2): Permanent breakage of module may occur if the module is used beyond the maximum rating. The module can be normal operated under the conditions according to Section 9 “Electrical Characteristics”. Malfunctioning of the module may occur and the reliability of the module may deteriorate if the module is used beyond the conditions.

9 Electrical Characteristics

9.1 DC Electrical Characteristics

ITEM	SYMBOL	TEST CONDITION	MIN	TYPE	MAX	UNIT
Supply Voltage	VDD	22±3°C, 55±15%R.H	-	2.8	3.3	V
	VDDL	55±15%R.H 22±3°C,	-	1.8	2.0	V
	VCC_C	22±3°C, 55±15%R.H	9.5	10	10.5	V
High-level Input Voltage	V _{IH}	-	0.8× VDD	-	-	V
Low-level Input Voltage	V _{IL}	-	-	-	0.2× VDD	V
High-level Output Voltage	V _{OH}	VDD=3V , I _{OUT} = 200uA	0.9× VDD	-	-	V
Low-level Output Voltage	V _{OL}	VDD=3V , I _{OUT} = 200uA	-	-	0.1× VDD	V

Note : The VCC_C input must be kept in a stable value; ripple and noise are not allowed.

9.2 Electro-optical Characteristics

ITEM	SYMBOL	TEST CONDITION	MIN	TYPE	MAX	UNIT
Normal Mode Brightness	Lbr	All pixels ON(1) (VCC VCC generated by external)	95	120	-	cd/m2
Normal Mode Power Consumption	Pt	All pixels ON(1)	-	130	170	mW
ICC, Stand-By Current	ICC	VCC_C/VCC_R	-	-	10	uA
IDD, Stand-By Current	IDD	PSEL=VDD	-	-	60	uA
C.I.E(W)	(x)	x,y(CIE1931)	0.26	0.30	0.34	-
	(y)		0.29	0.33	0.37	-
C.I.E(R)	(x)	x,y(CIE1931)	0.61	0.65	0.69	-
	(y)		0.30	0.34	0.38	-
C.I.E(G)	(x)	x,y(CIE1931)	0.26	0.30	0.34	-
	(y)		0.57	0.61	0.65	-
C.I.E(B)	(x)	x,y(CIE1931)	0.10	0.14	0.18	-
	(y)		0.13	0.17	0.21	-
Dark Room Contrast	CR	-	≥10000:1	-	-	-
Response Time	-	-	-	10	-	μ s
View Angle	-	-	≥160	-	-	Degree

Note: Normal Mode test conditions are as follows:

- Driving voltage : VCC_C=10V.
- Contrast setting : write_d(0x0b); R
write_d(0x0f); R
write_d(0x04); G
write_d(0x00); G
write_d(0x03); B
write_d(0x01); B
- Duty setting : 1/84

9.3 AC Electrical Characteristics

Serial Interface

Writing Timing

(Ta = 25°C, VSS =0V, VDD=2.8V, VCC_C =10V, CL=100pF)

Parameter	Symbol	Related Pins	Specification		Unit
			MIN	MAX	
Write Cycle Time	Tcyc	SCL(D0)	100	-	ns
Address Setup Time	Tswds	A0	65		ns
Address Hold Time	Tswdh	A0	35		ns
Select Setup Time	Tcws	CSB	65		ns
Select Hold Time	Tcwh	CSB	35		ns
SCL Low Pulse Width	Tscll	SCL(D0)	45		ns
Write High Pulse Width	Tsclh	SCL(D0)	45		ns
Select High Pulse Width	Tcsbh	CSB	30		ns
Data Setup Time	Twdts	SDA(D1)	20		ns
Data Hold Time	Twdth	SDA(D1)	30		ns
Rising Time	Tr	A0, CSB, SDA, SCL	-	30	ns
Falling Time	Tf	A0, CSB, SDA, SCL	-	30	ns

(Ta = 25°C, VSS =0V, VDD=1.65V ~ 2.0V, VCC_C=10V, CL=100pF)

Parameter	Symbol	Related Pins	Specification		Unit
			MIN	MAX	
Write Cycle Time	Tcyc	SCL(D0)	150	-	ns
Address Setup Time	Tswds	A0	65		ns
Address Hold Time	Tswdh	A0	60		ns
Select Setup Time	Tcws	CSB	65		ns
Select Hold Time	Tcwh	CSB	60		ns
SCL Low Pulse Width	Tscll	SCL(D0)	60		ns
Write High Pulse Width	Tsclh	SCL(D0)	60		ns
Select High Pulse Width	Tcsbh	CSB	100		ns
Data Setup Time	Twdts	SDA(D1)	60		ns
Data Hold Time	Twdth	SDA(D1)	60		ns
Rising Time	Tr	A0, CSB, SDA, SCL	-	30	ns
Falling Time	Tf	A0, CSB, SDA, SCL	-	30	ns

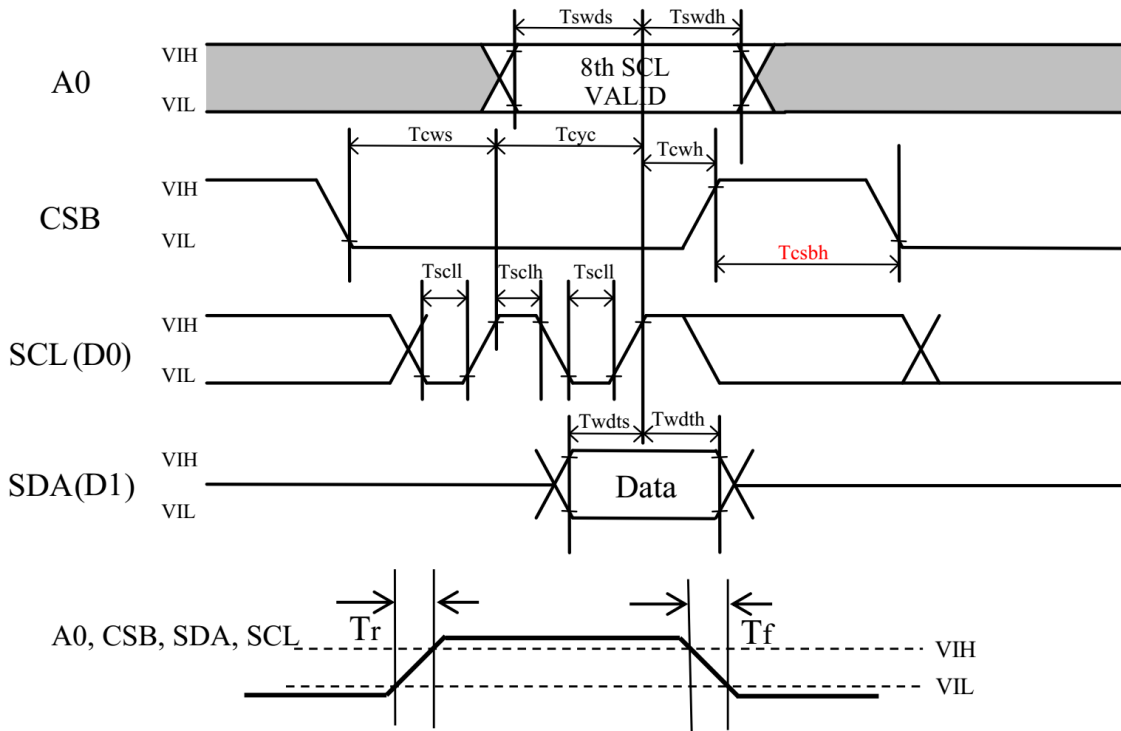

10 Functional Specification and Application Circuit

10.1 Power ON and Power OFF Sequence

Power Sequence:

PSEL = VDD, $C_{VDDL} = 2\mu\text{F}$

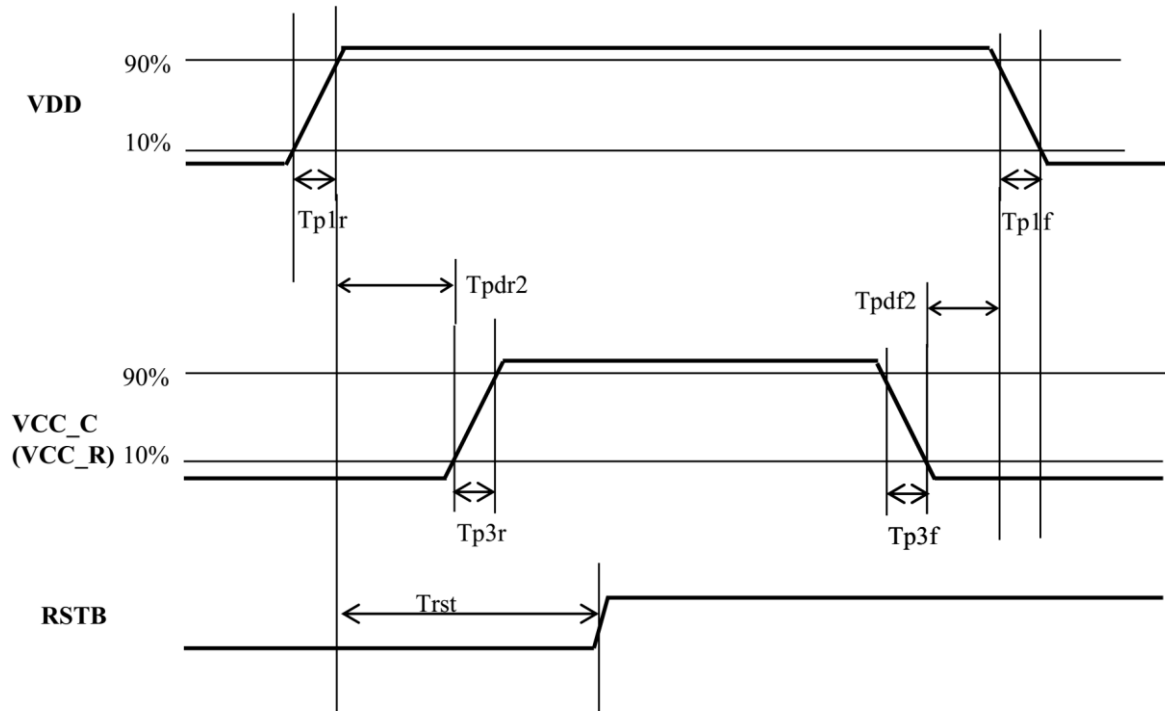

($T_a = 25^\circ\text{C}$, $V_{SS} = 0\text{V}$, $V_{DD} = 2.8\text{V}$, $V_{CC_C} = V_{CC_R} = 13\text{V}$, $RGBPRE = 0\text{V}$, $C_L = 100\text{pF}$)

Parameter	Symbol	Related Pins	Specification			Unit
			MIN	TYP	MAX	
VDD On Slope VDD Off Slope	T_{p1r} T_{p1f}	VDD	0.2	1	5	ms/V
VCC_C(VCC_R) On Slope VCC_C(VCC_R) Off Slope	T_{p3r} T_{p3f}	VCC_C(VCC_R)	0.2	1	5	ms/V
From VDD to VCC_C(VCC_R) Delay	T_{pdr2}	VDD, VCC_C(VCC_R)	2	-	-	ms
From VCC_C(VCC_R) to VDD Delay	T_{pdf2}	VDD, VCC_C(VCC_R)	2	-	-	ms
From VDD to H/W Reset Release	T_{rst}	VDD, RSTB	30	-	-	ms

Power sequence('CONT) :

PSEL = VSS

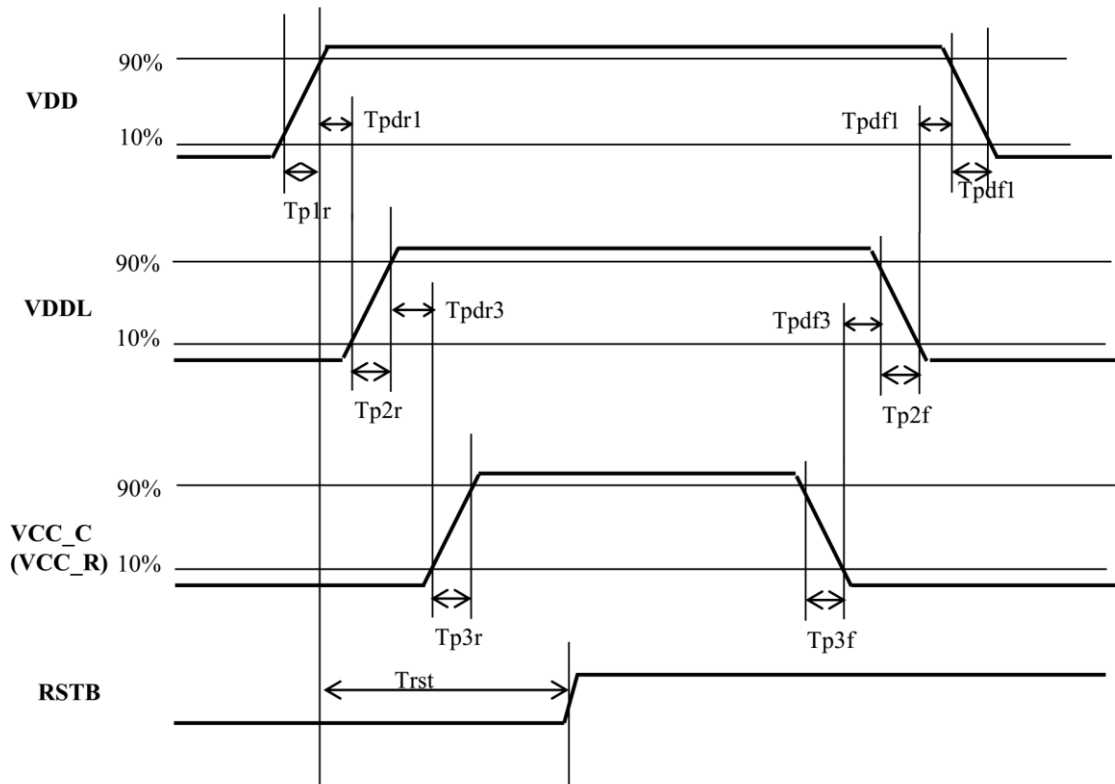

(Ta = 25°C, VSS =0V, VDD=2.8V, VCC_C=VCC_R=13V, RGBPRE=0V, CL=100pF)

Parameter	Symbol	Related Pins	Specification			Unit
			MIN	TYP	MAX	
VDDL On Slope VDDL Off Slope	Tp2r Tp2f	VDDL	0.2	1	5	ms/V
From VDD to VDDL Delay	Tpdr1	VDD, VDDL	1	-	-	ms
From VDDL to VDD Delay	Tpdf1	VDD, VDDL	1	-	-	ms
From VDDL to VCC_C(VCC_R) Delay	Tpdr3	VDDL, VCC_C(VCC_R)	1	-	-	ms
From VCC_C(VCC_R) to VDDL Delay	Tpdf3	VDDL, VCC_C(VCC_R)	1	-	-	ms
From VDD to H/W Reset Release	Trst	VDD, RSTB	30	-	-	ms

10.2 Application Circuit

10.2.1 The configuration (Serial Interface) VCC generated by external Circuit is shown in the following diagram, VDDL and VCC_R is generated internally. VDD=3.3V ~ 2V, VDD Reg. ON:

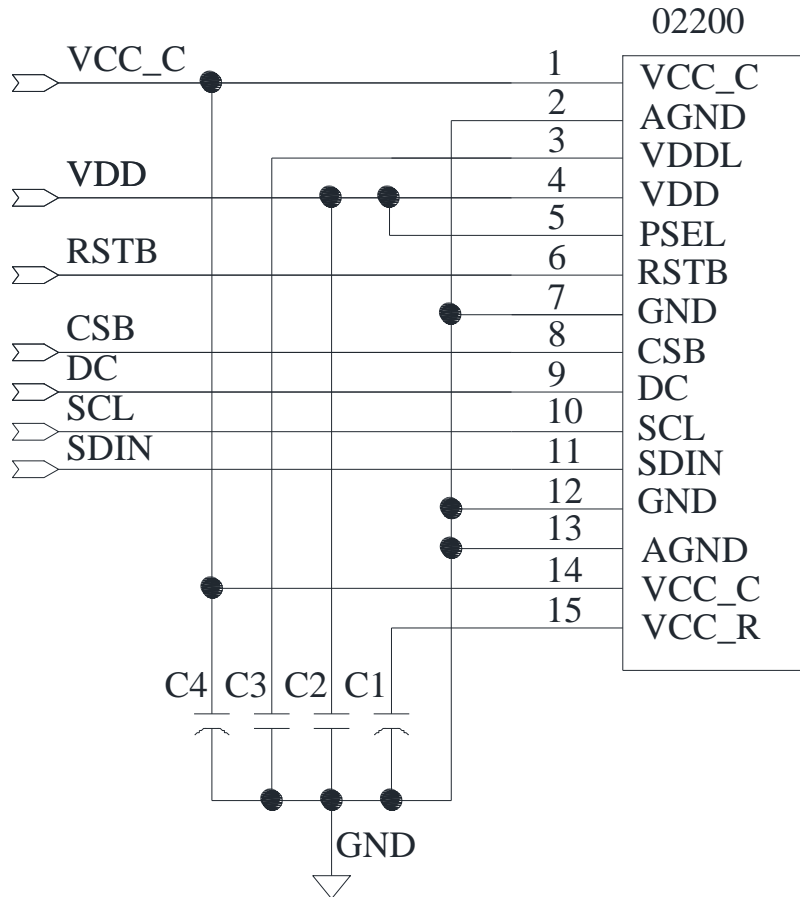

Pin connected to MCU interface: RSTB,CSB,DC,SCL,SDIN.

Recommended components

C1,C4 : 4.7 μ F/25V.RoHS (Tantalum Capacitors)

C2,C3: 1.0uF-0603-X7R \pm 10%.RoHS

10.2.2 The configuration (Serial Interface) VCC generated by external Circuit is shown in the following diagram, VDDL is generated by external Circuit. VDD=1.9V ~ 1.65V, VDD Reg. OFF:

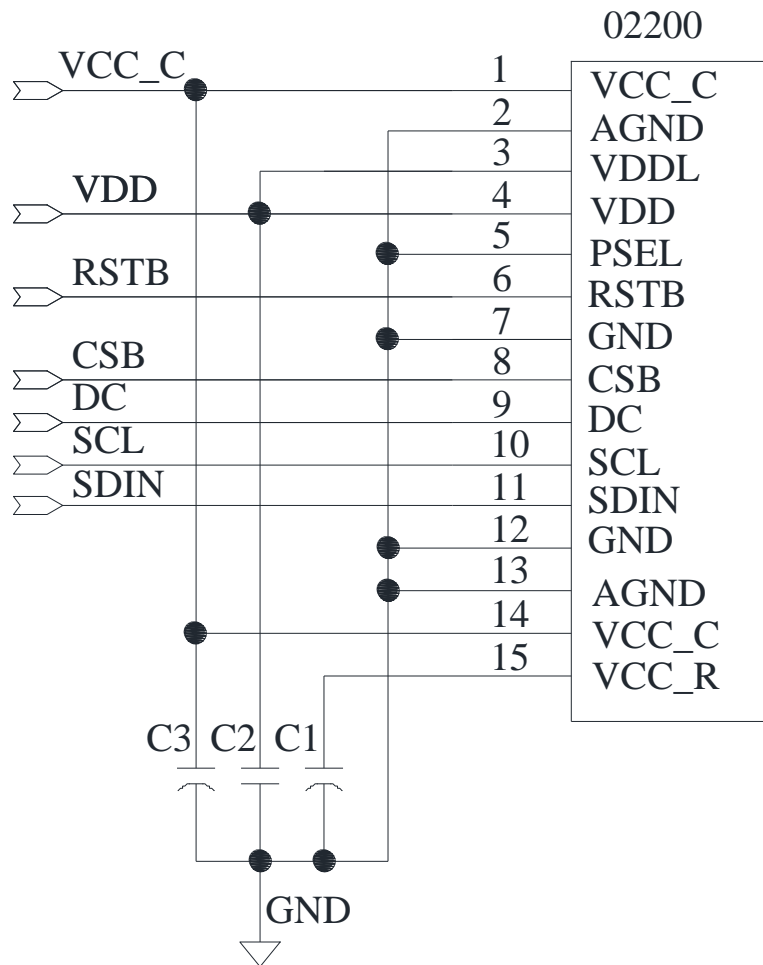

Pin connected to MCU interface: RSTB,CSB,DC,SCL,SDIN.

Recommended components

C1,C3 : 4.7 μ F/25V.RoHS (Tantalum Capacitors)

C2 : 1.0uF-0603-X7R \pm 10%.RoHS

10.3 Display Control Instruction

Refer to LD7138 IC Specification.

10.4 Recommended Software Initialization

In order to ensure the reliability and stability of the module, the module must initialize use the following code, Malfunctioning of the module may occur and the reliability of the module may deteriorate if the module is used beyond the initialize code.



```
void Init_IC()
{
    write_c(0x01);    //Software Reset
    write_c(0x02);    // Set Dot Matrix Display ON/OFF
    write_d(0x00);    //OFF
    write_c(0x03);    // Set Dot Matrix Display Stand-by ON/OFF
    write_d(0x00);    // Indicates the dot oscillator is starting.
    write_c(0x04);    // Set OSC Control
    write_d(0x04);    //    04
    write_c(0x05);    // Set Graphic RAM Writing Direction
    write_d(0x00);    //
    write_c(0x06);    // Set Row Scan Direction
    write_d(0x00);
    write_c(0x07);    //Set Display Size
    write_d(0x01);    //Xstart 1    00
    write_d(0x06);    //Xstart 2    00
    write_d(0x06);    //Xend 1    07
    write_d(0x09);    //Xend 2    0f
    write_d(0x02);    //Ystart 1    00
    write_d(0x0C);    //Ystart 2    00
    write_d(0x07);    //Yend 1    05
    write_d(0x0F);    //Yend 2    0F
    write_c(0x08);    //Set Interface Bus Type
    write_d(0x01);    //8Bit I/F Bus
    write_c(0x09);    //Set Masking Data
    write_d(0x07);    //Output Data
    write_c(0x0A);    // Set Read/Write Box Data
    write_d(0x01);    //Xstart 1
    write_d(0x06);    //Xstart 2
    write_d(0x06);    //Xend 1
    write_d(0x09);    //Xend 2
    write_d(0x02);    //Ystart 1
```

```

write_d(0x0C);    //Ystart 2
write_d(0x07);    //Yend 1
write_d(0x0F);    //Yend 2
write_c(0x0B);    //Set Display Start Address
write_d(0x00);    //1st Parameter
write_d(0x00);    //2nd Parameter
write_d(0x00);    //3rd Parameter
write_d(0x00);    //4th Parameter
write_c(0x0E);    //Set Dot Matrix Current Level
write_d(0x0b);    //1th Parameter      R //C
write_d(0x0f);    //2th Parameter      R //0
write_d(0x04);    //3rd Parameter      G //1
write_d(0x00);    //4th Parameter      G //8
write_d(0x03);    //5st Parameter      B //3
write_d(0x01);    //6nd Parameter      B //4
write_c(0x0F);    //Set Dot Matrix Peak Current Level
write_d(0x3f);    //1rd Parameter      R
write_d(0x3f);    //2nd Parameter      G
write_d(0x3f);    //3st Parameter      B
write_c(0x1C);    //Set Pre-Charge Width
write_d(0x1E);    //03
write_c(0x1D);    //Set Peak Pulse Width
write_d(0x1E);    //R   01
write_d(0x1E);    //G   01
write_d(0x1E);    //B   01
write_c(0x1E);    //Set Peak Pulse Delay
write_d(0x0A);    //   03
write_c(0x1F);    //Set Row Scan Operation
write_d(0x20);    //
write_c(0x30);    //Internal Regulator for Row Scan
write_d(0x11);    //Vcomh
write_c(0x3c);    // Set VDD Selection
write_d(0x00);    //0x01:1.8V   0x00:2.8V
Clear_screen();
write_c(0x02);    // Set Dot Matrix Display ON/OFF
write_d(0x01);    //ON
}

```

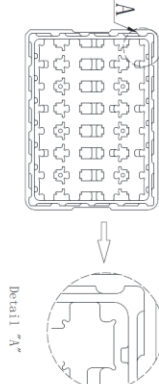
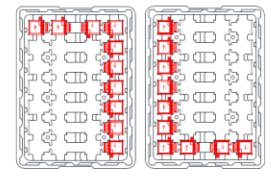
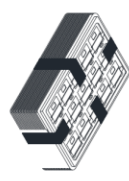
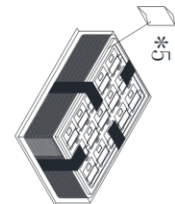
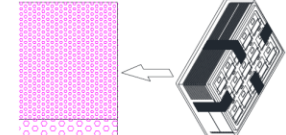
11 Package Specification

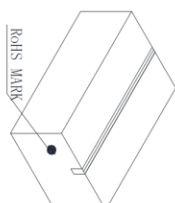
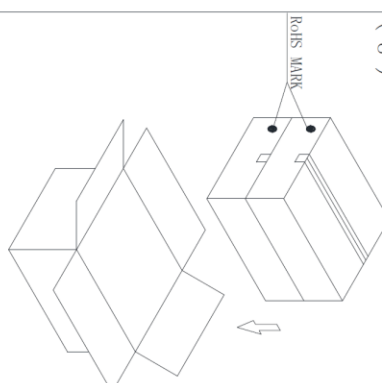
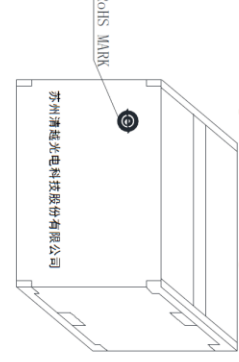
Controlled Seal		Packing Process (1)~(9)	
<p>(1) TRAY Type: 02200-MT5(中转)-A</p> 	<p>(2)</p>  <p>TRAY</p>	<p>(3) order ①、②、①、② fix trays with tape 1210 pcs of 1 small carton 1 tray contain 55 pcs 22 contained trays, 1 empty tray</p> 	<p>(4) package with plastic bags add five desiccants create a power vacuum</p>  <p>*5</p>
<p>(5) After tray be packed, wrap the package in a bubble bag and seal with scotch tape.</p> 	<p>NOTE:1、 The inner carton and master carton must be sealed with adhesive tape. 2、 Fill up the gap with EPE. 3、 If the customer has special needs with the RoHS making, the inner carton and master carton need adhesive new RoHS marking at .</p> <p>4、 Packaging materials are not recommended for recycling.</p>	<p>(7)</p>  <p>small carton package</p>	<p>(8)</p>  <p>2 small cartons in 1 big carton</p>
<p>(9) 14 contained trays, 2 empty trays, Package quantity products: 2420 pcs of 1 big carton</p>  <p>Package finished L450*W350*L352 mm</p> <p>苏州清越光电科技股份有限公司 RoHS MARK</p>			

12 Reliability

12.1 Reliability Test

NO.	ITEM	CONDITION	QUANTITY
1	High Temperature (Non-operation)	85°C,240hrs	5
2	Low Temperature (Non-operation)	-40°C,240hrs	5
3	High Temperature (Operation)	70°C,240hrs	5
4	Low Temperature (Operation)	-40°C,240hrs	5
5	High Temperature / High Humidity (Operation)	60°C,90%RH,240hrs	5
6	Thermal shock (Non-operation)	-40 °C ~85 °C (-40 °C /30min;transit/5min;85 °C /30min;transit/5min) 1cycle: 70min,30cycles	5
7	ESD Air discharge (Non-operation)	± 8kV, Test 9 point; Each point discharge 10 times. Time interval is less than 1 second.	5

Test and measurement conditions

- All measurements shall not be started until the specimens attain to temperature stability, the stable time is at least 15 minutes.
- The degradation of polarizer is ignored for item 5.
- The tolerance of temperature is $\pm 3^{\circ}\text{C}$, and the tolerance of relative humidity is $\pm 5\%$.

Evaluation criteria

- The function test is OK.
- No observable defects.
- Luminance: $\geq 50\%$ of initial value.
- Current consumption: within $\pm 50\%$ of initial value.

12.2 Lifetime

End of lifetime is specified as 50% of initial brightness and the test pattern at operating condition is 50% alternating checkerboard.

ITEM	MIN	MAX	UNIT	CONDITION
Operation Life Time	5,000	-	hrs	120 cd/m ² , 50% alternating checkerboard, 22±3 °C, 55±15% RH

12.3 Failure Check Standard

After the completion of the described reliability test, the samples were left at room temperature for 2 hrs prior to conducting the failure test at 22±3 °C; 55±15% RH.

13 Illustration of OLED Product Name

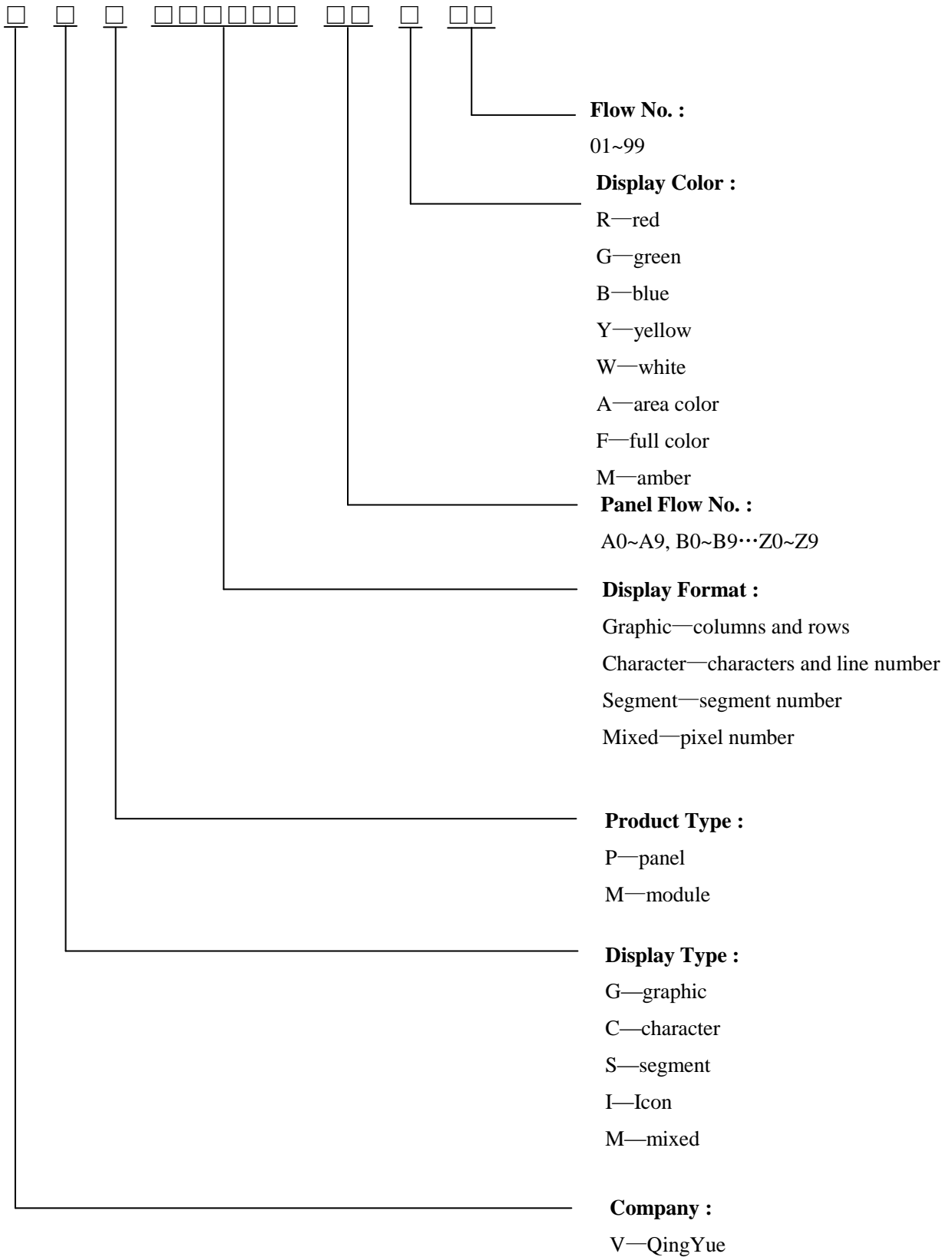

14 Outgoing Quality Control Specifications

14.1 Sampling Method

- (1) GB/T 2828.1/ISO2859-1: inspection level II , normal inspection, single sample inspection
- (2) AQL: Major 0.65; Minor 1.0

14.2 Inspection Conditions

The environmental conditions for test and measurement are performed as follows.

Temperature: $22 \pm 3^{\circ}\text{C}$

Humidity: $55 \pm 15\% \text{R.H}$

Fluorescent Lamp: 30W

Distance between the Panel & Lamp: $\geq 50\text{cm}$

Distance between the Panel & Eyes: $\geq 30\text{cm}$

Viewing angle from the vertical in each direction: $\leq 45^{\circ}$

(See the sketch below)

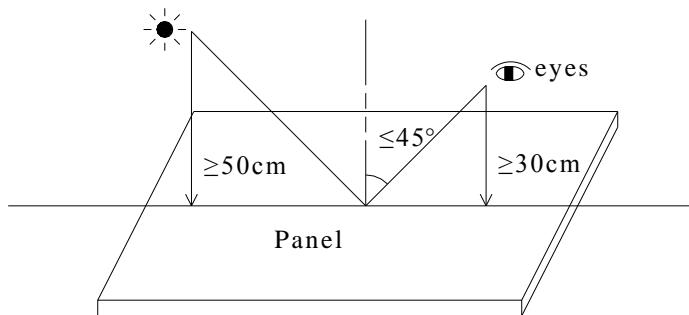

14.3 Quality Assurance Zones

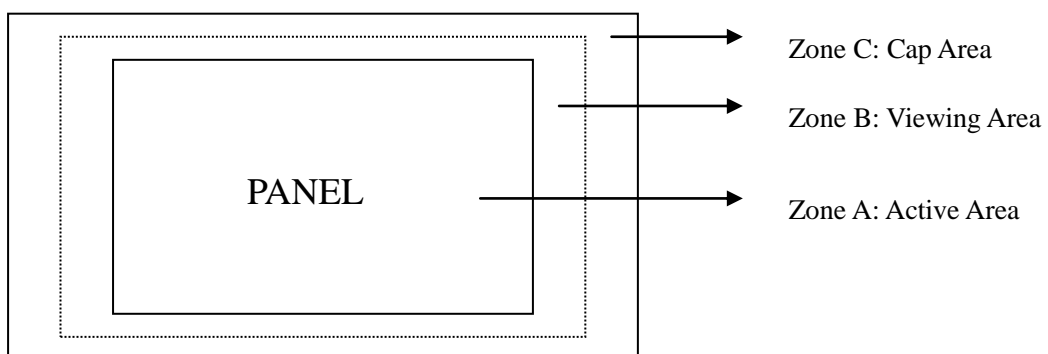

14.4 Inspection Standard

Definition of Φ &L&W (Unit: mm)

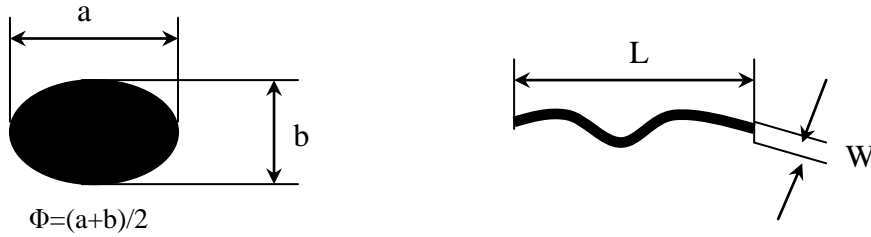

I . Appearance Defects

NO.	ITEM	CRITERIA	CLASSIFICATION																	
1	Polarizer Black or White spot, Dirty spot, Foreign matter, Dent on the polarizer	<table border="1"> <thead> <tr> <th rowspan="2">Average Diameter (mm)</th> <th colspan="2">Acceptable Number</th> </tr> <tr> <th>Zone A,B</th> <th>Zone C</th> </tr> </thead> <tbody> <tr> <td>$\Phi \leq 0.15$</td> <td colspan="2">Ignore</td> </tr> <tr> <td>$0.15 < \Phi \leq 0.30$</td> <td>3</td> <td rowspan="2">Ignore</td> </tr> <tr> <td>$\Phi > 0.30$</td> <td>0</td> </tr> </tbody> </table>	Average Diameter (mm)	Acceptable Number		Zone A,B	Zone C	$\Phi \leq 0.15$	Ignore		$0.15 < \Phi \leq 0.30$	3	Ignore	$\Phi > 0.30$	0	Minor				
Average Diameter (mm)	Acceptable Number																			
	Zone A,B	Zone C																		
$\Phi \leq 0.15$	Ignore																			
$0.15 < \Phi \leq 0.30$	3	Ignore																		
$\Phi > 0.30$	0																			
2	Scratch/line on the glass/Polarizer	<table border="1"> <thead> <tr> <th rowspan="2">Width (mm)</th> <th rowspan="2">Length (mm)</th> <th colspan="2">Acceptable Number</th> </tr> <tr> <th>Zone A,B</th> <th>Zone C</th> </tr> </thead> <tbody> <tr> <td>$W \leq 0.05$</td> <td>---</td> <td colspan="2">Ignore</td> </tr> <tr> <td>$0.05 < W \leq 0.1$</td> <td>$L \leq 5.0$</td> <td>3</td> <td rowspan="2">Ignore</td> </tr> <tr> <td>$W > 0.1$</td> <td>---</td> <td>0</td> </tr> </tbody> </table>	Width (mm)	Length (mm)	Acceptable Number		Zone A,B	Zone C	$W \leq 0.05$	---	Ignore		$0.05 < W \leq 0.1$	$L \leq 5.0$	3	Ignore	$W > 0.1$	---	0	Minor
Width (mm)	Length (mm)	Acceptable Number																		
		Zone A,B	Zone C																	
$W \leq 0.05$	---	Ignore																		
$0.05 < W \leq 0.1$	$L \leq 5.0$	3	Ignore																	
$W > 0.1$	---	0																		
3	Polarizer Bubble	<table border="1"> <thead> <tr> <th rowspan="2">Average Diameter (mm)</th> <th colspan="2">Acceptable Number</th> </tr> <tr> <th>Zone A,B</th> <th>Zone C</th> </tr> </thead> <tbody> <tr> <td>$\Phi \leq 0.2$</td> <td colspan="2">Ignore</td> </tr> <tr> <td>$0.2 < \Phi \leq 0.5$</td> <td>3</td> <td rowspan="2">Ignore</td> </tr> <tr> <td>$\Phi > 0.5$</td> <td>0</td> </tr> </tbody> </table>	Average Diameter (mm)	Acceptable Number		Zone A,B	Zone C	$\Phi \leq 0.2$	Ignore		$0.2 < \Phi \leq 0.5$	3	Ignore	$\Phi > 0.5$	0	Minor				
Average Diameter (mm)	Acceptable Number																			
	Zone A,B	Zone C																		
$\Phi \leq 0.2$	Ignore																			
$0.2 < \Phi \leq 0.5$	3	Ignore																		
$\Phi > 0.5$	0																			
4	Any Dirt & Scratch on Polarizer's Protective Film	Ignore for not affect the polarizer.	Minor																	
5	Any Dirt on Cap Glass	Inside the Cap, Ignore the dirt without moving.	Minor																	

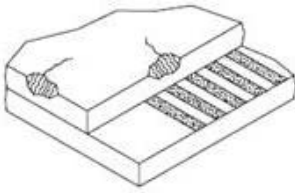
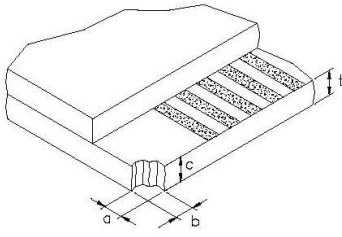
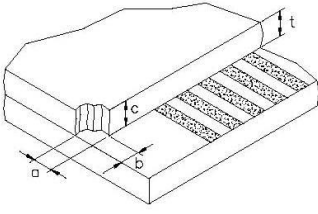
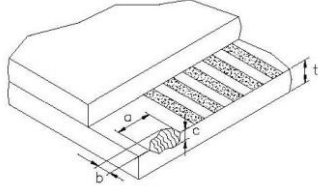
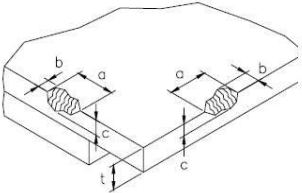
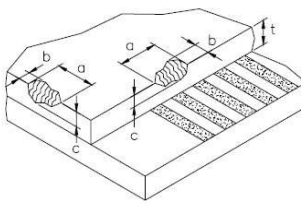
6	Glass Crack		Propagation crack is not acceptable.	Major
7	Corner Chip		t= Glass thickness Accept $a \leq 2.0\text{mm}$ or $b \leq 2.0\text{mm}$, $c \leq t$	Minor
8	Corner Chip on Cap Glass		t= Glass thickness Accept $a \leq 1.5\text{mm}$ or $b \leq 1.5\text{mm}$, $c \leq t$	Minor
9	Chip on Contact Pad		t= Glass thickness Accept $a \leq 2.0\text{ mm}$ or $b \leq 0.5\text{mm}$, $c \leq t$ (on the contact pin) $a \leq 2.0\text{ mm}$ or $b \leq 1.5\text{mm}$, $c \leq t$ (outside of the contact pin)	Minor
10	Chip on Face of Display		t= Glass thickness Accept $a \leq 1.5\text{mm}$ or $b \leq 1.5\text{mm}$, $c \leq t$	Minor
11	Chip on Cap Glass		t= Glass thickness Accept $a \leq 2.0\text{mm}$ or $b \leq 2.0\text{mm}$, $c \leq t/2$ $a \leq 1.5\text{mm}$ or $b \leq 1.5\text{mm}$, $t/2 \leq c \leq t$	Minor
12	Stain on Surface	Stain removable by soft cloth or air blow is acceptable.		Minor
13	TCP/FPC Damage	(1) Crack, deep scratch, deep hole and deep pressure mark on the TCP/FPC are not acceptable. (2) Terminal lead twisted or broken is not allowable. (3) Copper exposed is not allowed by naked eye inspection.		Minor
14	Dimension Unconformity	Checking by mechanical drawing.		Major

II. Displaying Defects

NO.	Items	Criteria	Classification														
1	Black/White spot Dirty spot Foreign matter	<table border="1"> <thead> <tr> <th rowspan="2">Average Diameter (mm)</th> <th colspan="2">Pieces Permitted</th> </tr> <tr> <th>Zone A,B</th> <th>Zone C</th> </tr> </thead> <tbody> <tr> <td>$\Phi \leq 0.10$</td> <td colspan="2">Ignore</td> </tr> <tr> <td>$0.10 < \Phi \leq 0.20$</td> <td colspan="2">3</td> </tr> <tr> <td>$\Phi > 0.20$</td> <td colspan="2">0</td> </tr> </tbody> </table>	Average Diameter (mm)	Pieces Permitted		Zone A,B	Zone C	$\Phi \leq 0.10$	Ignore		$0.10 < \Phi \leq 0.20$	3		$\Phi > 0.20$	0		Minor
Average Diameter (mm)	Pieces Permitted																
	Zone A,B	Zone C															
$\Phi \leq 0.10$	Ignore																
$0.10 < \Phi \leq 0.20$	3																
$\Phi > 0.20$	0																
2	No Display	Not allowable.	Major														
3	Irregular Display	Not allowable.	Major														
4	Missing Line (row or column)	Not allowable.	Major														
5	Abnormal Color	Refer to the SPEC.	Major														
6	Luminance NG	Refer to the SPEC.	Major														

15 Precautions for operation and Storage

15.1 Precautions for Operation

- (1) Since OLED panel is made of glass, do not apply any mechanical shock or impact or excessive force to it when installing the OLED module. Any strong mechanical impact due to falling dropping etc. may cause damage (breakage or cracking).
- (2) The polarizer on the OLED surface is made of soft material and is easily scratched. Please take most care when handing. When the surface of the polarizer of OLED Module is contaminated, please wipe it off gently by using moisten soft cloth with isopropyl alcohol, do not use water, ketone or aromatics. If there is saliva or water on the OLED surface, please wipe it off immediately.
- (3) When handling OLED module, please be sure that the body and the tools are properly grounded. And do not touch I/O pins with bare hands or contaminate I/O pins, it will cause disconnection or defective insulation of terminals.
- (4) Do not attempt to disassemble or process the OLED module.
- (5) OLED module should be used under recommended operating conditions shown in the specification. Since the higher voltage leads to the shorter lifetime, be sure to use the specified operating voltage.
- (6) Foggy dew, moisture condensation or water droplets deposited on surface and contact terminals will cause polarizer stain or damage, the deteriorated display quality and electrochemical reaction then leads to shorter life time and permanent damage to the module probably. Please pay attention to the environmental temperature and humidity.
- (7) An afterimage is created by the difference in brightness between unused dot and the fixed dot, according to the decrease of brightness of the emitting time. Therefore, to avoid having an afterimage, the full set should be thoroughly used instead of using a fixed dot. When the fixed dot emits, an afterimage can be created.
- (8) Flicker could be come out at full on display. And it disappears when frame frequency increase, but brightness decreases too.

15.2 Soldering

- (1) Soldering should be performed only on the I/O terminals.
- (2) Use soldering irons with proper grounding and no leakage.
- (3) Iron: The temperature setting of electric iron is 350°C, but we suggest that during soldering, the temperature of iron tip should be no higher than 330°C and soldering be finished within 3~4 seconds.

15.3 Precautions for Storage

- (1) Please store OLED module in a dark place. Avoid exposure to sunlight, the light of fluorescent lamp or any ultraviolet ray.
- (2) Keep the environment temperature between 10°C and 35°C and the relative humidity less than 70%. Avoid high temperature and high humidity.
- (3) Keep the OLED modules stored in the container when shipped from supplier before using them is recommended.
- (4) Do not leave any article on the OLED module surface for an extended period of time.

15.4 Warranty period

QingYue warrants for a period of 12 months from the shipping date when stored or used under normal condition. In addition to failure and quality problems caused by man-made damage and force majeure, we promise to provide maintenance and replacement free of charge during the warranty period. If the warranty period has been exceeded, we need to collect the staff's travel expenses, materials and other related costs.