

SPECIFICATION FOR CTP MODULE

MODULE NO: YB-TG19201080C17A-C-A0

Doc.Version:01

Customer Approval:

<input type="checkbox"/> Accept	<input type="checkbox"/> Reject
---------------------------------	---------------------------------

YEEBO	NAME	SIGNATURE	DATE
Prepare	Electronic Engineer	邹伟林	2022-09-27
Check	Mechanical Engineer		
Verify			
Approval			

■ APPROVAL FOR SPECIFICATIONS ONLY

APPROVAL FOR SPECIFICATIONS AND SAMPLE

WIMRD005-02-D



2. Table of Contents:

NO	CONTENTS	PAGE
1	Revision History	1
2	Table of Contents	2
3	Module Numbering System	3
4	General Specification	4
5	Dimensional Outline	5
6	Electrical Characteristics	6
7	Optical Characteristics	14
8	Interface Pin Assignment	18
9	Block Diagram	20
10	Backlight	21
11	Standard Specification for Reliability	22
12	Specification of Quality Assurance	24
13	Handling Precaution	29
14	Warranty	30
15	Guarantee	30



3. Module Numbering System:
(example)

YB- TG 19201080 C 17 A-C - A 0

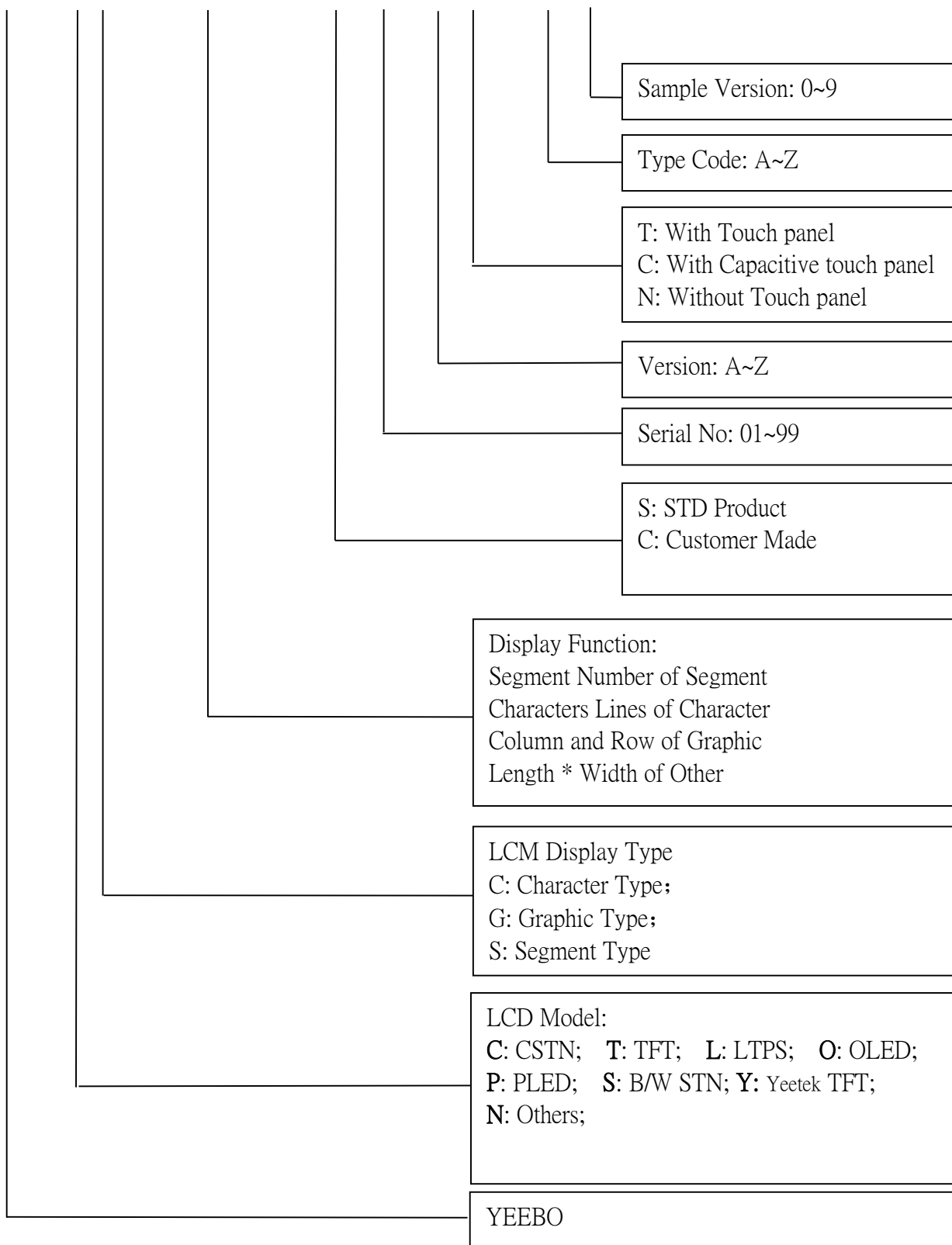



4. General Specification:

ITEM	SPECIFICATION
Structure	G + G + TFT
Screen Size	21.5 Inch
Display Format	1920(RGB) * 1080 Pixels
Module Size(mm)	513.00 (W) * 304.50 (H) * 15.11 (T) mm
View Area(mm)	476.64(W) * 268.11(H)
Active Area(mm)	476.64(W) * 268.11(H)
Pixel Pitch(mm)	0.24825(W) × 0.24825(H)
LCD Type	16.7M Color / Transmissive / Normal Black
View Angle	Free
CTP Controller IC	ILI2510
CTP Interface	USB
Weight(g)	TBD
Firmware	TBD
Test Configuration	TBD

5. Dimensional Outline:

Count drawing & Specification record during discussion with customer
 Rec: 01
 Revision: current description
 Date: 2022-09-14
 FIRST ISSUE

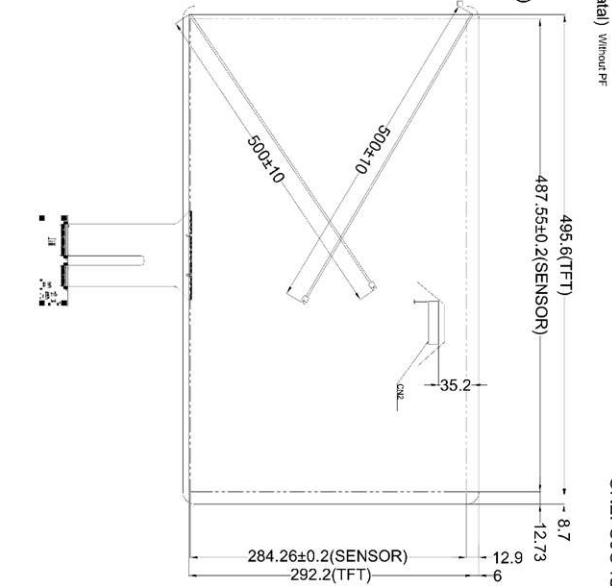
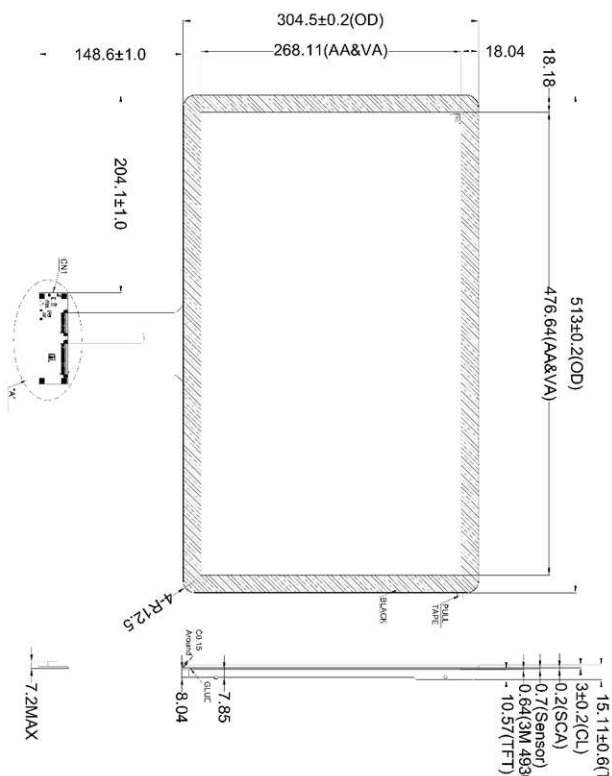

PIN	Definition	PIN	Definition
1	RX00-	16	RXE1+
2	RX00+	17	GND
3	RX01-	18	RXE2-
4	RX01+	19	RXE2+
5	RX02-	20	RXEC-
6	RX02+	21	RXEC+
7	GND	22	RXE3-
8	RX0C-	23	RXE3+
9	RX0C+	24	GND
10	RX03-	25	NC
11	RX03+	26	NC
12	RXE0-	27	NC
13	RXE0+	28	VDD
14	GND	29	VDD
15	RXE1-	30	VDD

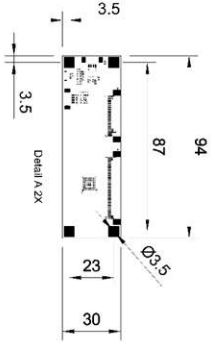

CN1: USB(4PIN) (2417RJ-04-SM02)

PIN	Definition
1	VBUS
2	DN
3	DP
4	GND

- Specification:**
1. Display mode: 21.5" TFT / Transmissive / Normal Black
 2. Display Color: 16.7M
 3. Viewing Direction: Free
 4. TFT mode: S01,R01,I21,S01ID=1500
 5. Operating temperature: -20°C to +80°C
 6. Storage temperature: -30°C to +85°C
 7. Unspecified tolerance: ±0.30mm.
 8. Glass type: G+G+TFT
 9. TP Controller IC: ILI2510
 11. ROHS compliant

YEEBO

MOD. Name: **YB-TG19201080C17A-C-A**

DESIGNED: 李名榮 2022/9/14
 CHECKED: 陳長品 2022/9/14
 VERIFIED: 李名榮 2022/9/14
 APPROVED: 李名榮 2022/9/14

UNIT: mm
 SIZE: A4
 SCALE: N-T-S

Sheet 1
 Of 1

FILE NAME: **Count Dwg.**

6. Electrical Characteristics

6-1 Absolute Maximum Ratings

6-1-1 TFT Absolute Maximum Ratings

(Ta=25°C)

< Table 2. Absolute Maximum Ratings >

[VSS=GND=0V]

Parameter	Symbol	Min.	Max.	Unit	Remarks
Power Supply Voltage	V _{DD}	-0.3	5.5	V	Ta = 25 °C
Logic Supply Voltage	V _{IN}	VSS-0.3	V _{DD} +0.3	V	
Operating Temperature	T _{OP}	-20	+80	°C	
Storage Temperature	T _{ST}	-30	+85	°C	
Liquid crystal clear point	T _{Lc}	104.9		°C	Typ.

6-1-2 TP Absolute Maximum Ratings

Parameter	Symbol	Min	Max	Unit
Chip power input	V _{DD}	-0.3	3.6	V
V _{DD3A} to GND	V _{DD3A}	-0.3	3.6	V
V _{DD3D} to GND	V _{DD3D}	-0.3	3.6	V
V _{DDIO} to GND	V _{DDIO}	-0.3	3.6	V
V _{DD16} to GND	V _{DD16}	-0.3	1.65	V
V _{GH} to GND	V _{GH}	-0.3	32	V
V _{TX} to GND	V _{TX}	-0.3	32	V
ESD Susceptibility HBM (Human Body Mode)(Note 1)	HBM		4000	V
ESD Susceptibility MM (Machine Mode)	MM		400	V

Note 1: Devices are ESD sensitive. Handling precaution is recommended.

6-2 Operating Conditions

6-2-1 TFT Operating Conditions

(Ta=25°C)

< Table 3. Electrical specifications >

[Ta =25±2 °C]

Parameter		Min.	Typ.	Max.	Unit	Remarks
Power Supply Voltage	V _{DD}	4.5	5.0	5.5	V	Note 1
Power Supply Current	I _{DD}	-	700	1200	mA	
In-Rush Current	I _{RUSH}	-	-	3	A	Note 2
Permissible Input Ripple Voltage	V _{RF}	-	-	300	mV	V _{DD} = 5.0V
High Level Differential Input Threshold Voltage	V _{IH}	-	-	+100	mV	
Low Level Differential Input Threshold Voltage	V _{IL}	-100	-	-	mV	
Differential input voltage	V _{ID}	200	-	600	mV	
Differential input common mode voltage	V _{cm}	1.0	1.2	1.5		V _{IH} =100mV, V _{IL} =-100mV
LED Voltage	V _L	-	5.6	6.6	V	
LED Channel Voltage	V _L	-	61.6	72.6	V	Duty 100%
LED Channel Current	I _L		68		mA	Duty 100%, Each channel
LED Lifetime		30000	-	-	Hrs	I _L =85 mA, Note 4
Power Consumption	P _D	-	3.5	5.4	W	
	P _{BL}	-	41.88		W	I _L =85mA, Note 3
	P _{total}	-	45.38		W	

Notes : 1. The supply voltage is measured and specified at the interface connector of LCM.

The current draw and power consumption specified is for VDD=5.0V, Frame rate=60Hz. Test Pattern of power supply current

- a) Typ : Color Bar pattern
- b) Max : Gray Level 255 Pattern

2. Duration of rush current is about 2 ms and rising time of VDD is 520 μs ± 20 %

3. Calculated value for reference (V_L × I_L) ×4(channel) excluding driver loss. (LED Light bar: 16S8P)

4. The lifetime is determined as the time at which luminance of LED become 50% of the initial brightness or not normal lighting at IPIN=90mA on condition of continuous operating at 25 ±2 °C

6-2-2 TP Operating Conditions

Parameter	Symbol	Min	Max	Unit
V _{DD} to GND input power supply voltage	V _{DD}	3.14	3.46	V
V _{DD3A} to GND	V _{DD3A}	3.14	3.46	V
V _{DD3D} to GND	V _{DD3D}	3.14	3.46	V
V _{DDIO} to GND	V _{DDIO}	1.8	3.46	V
V _{GH} to GND	V _{GH}	-0.3	32	V
V _{TX} to GND	V _{TX}	-0.3	32	V
Operating Ambient Temperature Range	T _A	-20	85	°C
Operating Junction Temperature Range	T _J	-40	125	°C
Storage Ambient Temperature Range	T _{ST}	-40	150	°C

Note: The device is not guaranteed to function outside its operating conditions.

Table 5-3: Input Power Supply

(V_{DD3A} = V_{DD3D} = 3.3V, Room Temperature)

Item	Symbol	Min	Typ.	Max	Unit	Condition
USB 3.3V input power supply voltage	V _{DD}	3.14	3.3	3.46	V	@ USB
Digital input power supply voltage*	V _{DD3D}	3.14	3.3	3.46	V	
Analog input power supply voltage	V _{DD3A}	3.14	3.3	3.46	V	
I/O input power supply voltage*	V _{DDIO}	1.8	3.3	3.46	V	

*If V_{DDIO} & V_{DD3D} is not supplied power, there is risk of I/O pin with current leakage

6-3 Timing Characteristics

6-3-1 The TFT is operated by the DE only

Item		Symbols	Min	Typ	Max	Unit
Clock	Frequency	1/Tc	63	74.25	88	MHz
	High Time	-	-	4/7Tc	-	
	Low Time	-	-	3/7Tc	-	
Frame Period		Tv	1100	1125	1200	line
			55	60	65	Hz
			15.38	16.67	18.18	ms
Vertical Display Period		Tvd	-	1080	-	line
One line Scanning Period		Th	1050	1100	1120	clocks
Horizontal Display Period		Thd	-	960	-	clocks

6-3-2 TFT LVDS Rx Interface Timing Parameter

The specification of the LVDS Rx interface timing parameter is shown in Table 4.

<Table 4. LVDS Rx Interface Timing Specification>

Item	Symbol	Min	Typ	Max	Unit	Remark
CLKIN Period	tRCIP	10.76	13.46	16.15	nsec	
Input Data 0	tRIP1	-0.4	0.0	+0.4	nsec	
Input Data 1	tRIP0	tRCIP/7-0.4	tRCIP/7	tRCIP/7+0.4	nsec	
Input Data 2	tRIP6	2 × tRCIP/7-0.4	2 × tRCIP/7	2 × tRCIP/7+0.4	nsec	
Input Data 3	tRIP5	3 × tRCIP/7-0.4	3 × tRCIP/7	3 × tRCIP/7+0.4	nsec	
Input Data 4	tRIP4	4 × tRCIP/7-0.4	4 × tRCIP/7	4 × tRCIP/7+0.4	nsec	
Input Data 5	tRIP3	5 × tRCIP/7-0.4	5 × tRCIP/7	5 × tRCIP/7+0.4	nsec	
Input Data 6	tRIP2	6 × tRCIP/7-0.4	6 × tRCIP/7	6 × tRCIP/7+0.4	nsec	

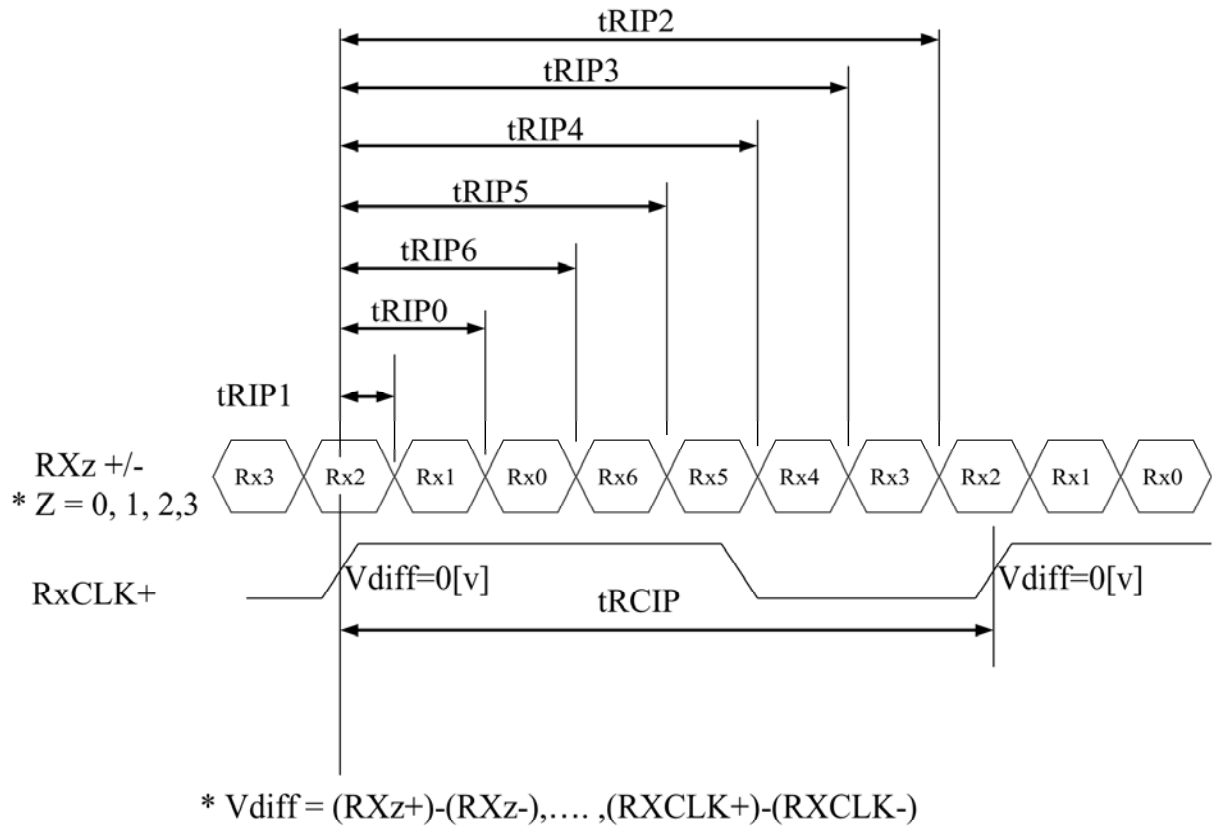

6-3-3 TFT Power Sequence

To prevent a latch-up or DC operation of the LCD module, the power on/off sequence shall be as shown in below

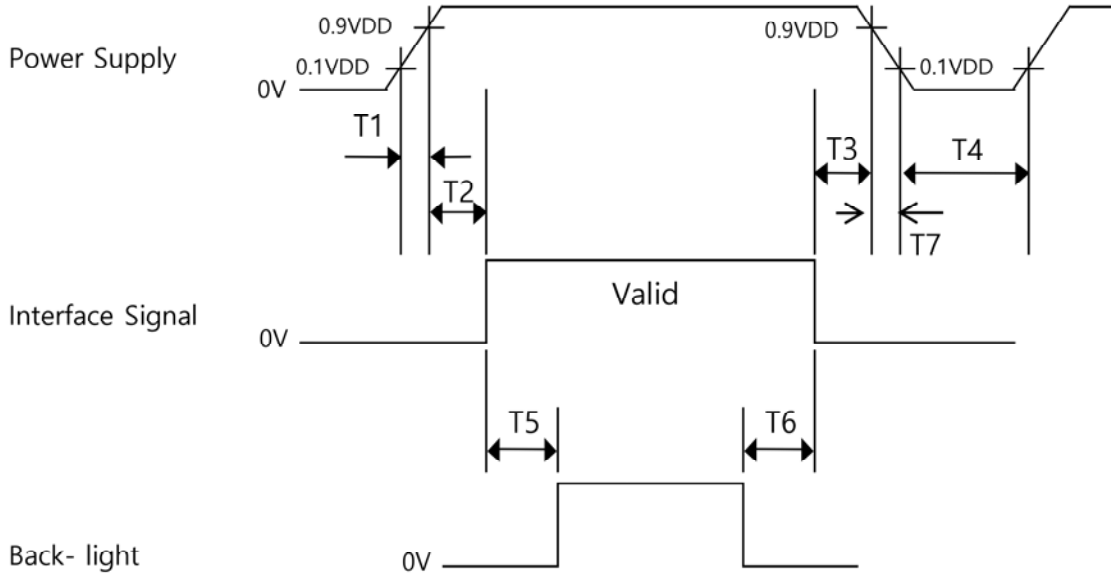

- $0.5 \text{ ms} \leq T1 \leq 10 \text{ ms}$
- $0 \leq T2 \leq 50 \text{ ms}$
- $0 \leq T3 \leq 50 \text{ ms}$
- $1 \text{ sec} \leq T4$
- $200 \text{ ms} \leq T5$
- $200 \text{ ms} \leq T6$

Notes:

1. When the power supply VDD is 0V, keep the level of input signals on the low or keep high impedance.
2. Do not keep the interface signal high impedance when power is on.
3. Back Light must be turn on after power for logic and interface signal are valid.
4. T7 decreases smoothly, there is none re-bouncing voltage.
5. During changing the resolution or mode changing, the logic power/ back-light/interface signal should be turned off as shown above; after the changing, power on as shown above.

6-3-4 TP Power Sequence

6-3-4-1 Power-on Sequence

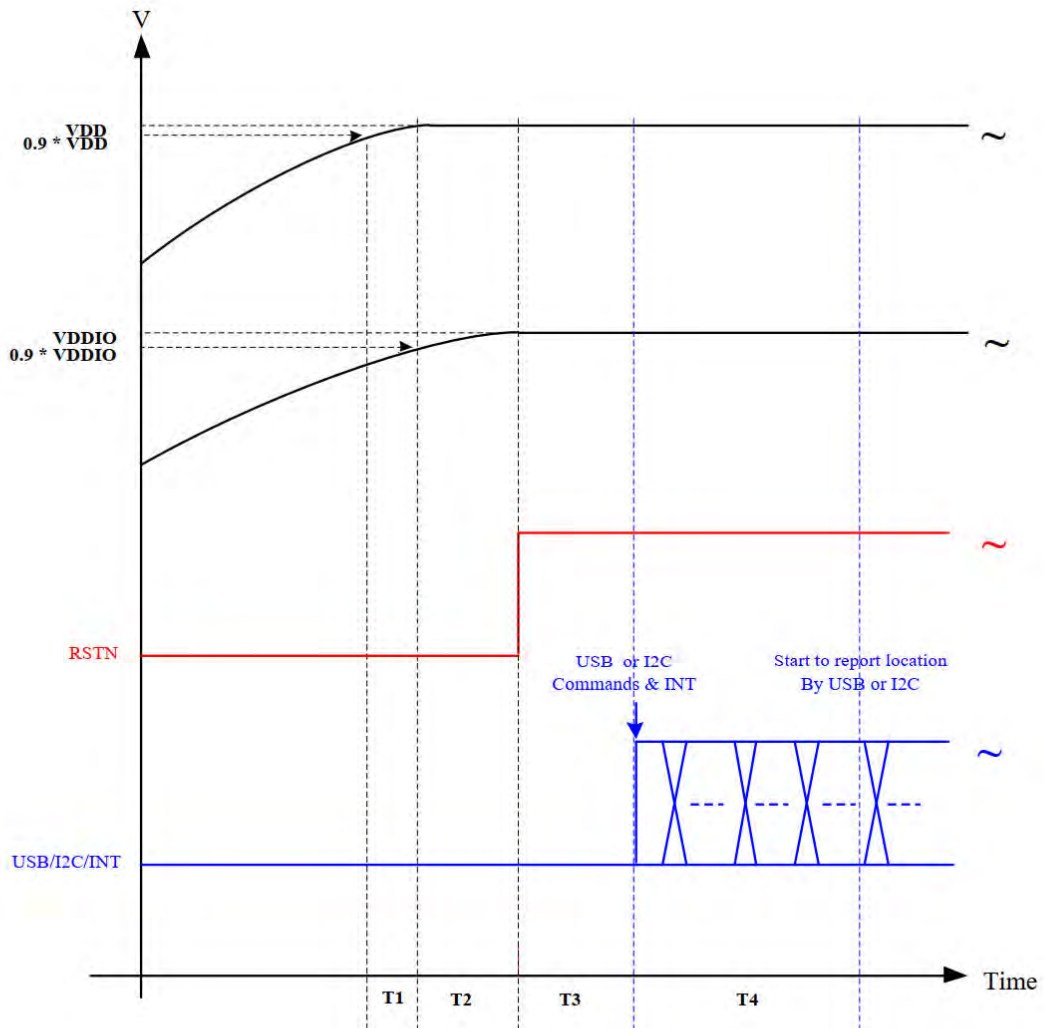

1. T1: the time difference between $0.9 * VDD$ and $0.9 * VDDIO$. T1 must be ≥ 0 sec.
2. T2: the time difference between $0.9 * VDDIO$ and RSTN. T2 must be ≥ 200 us.
3. T3: the time difference between RSTN and Commands. T3 must be ≥ 150 ms.
4. T4: IC start to report point location to host. T4 must be ≥ 300 ms.

6-3-4-2 Power-off to Power-on Sequence

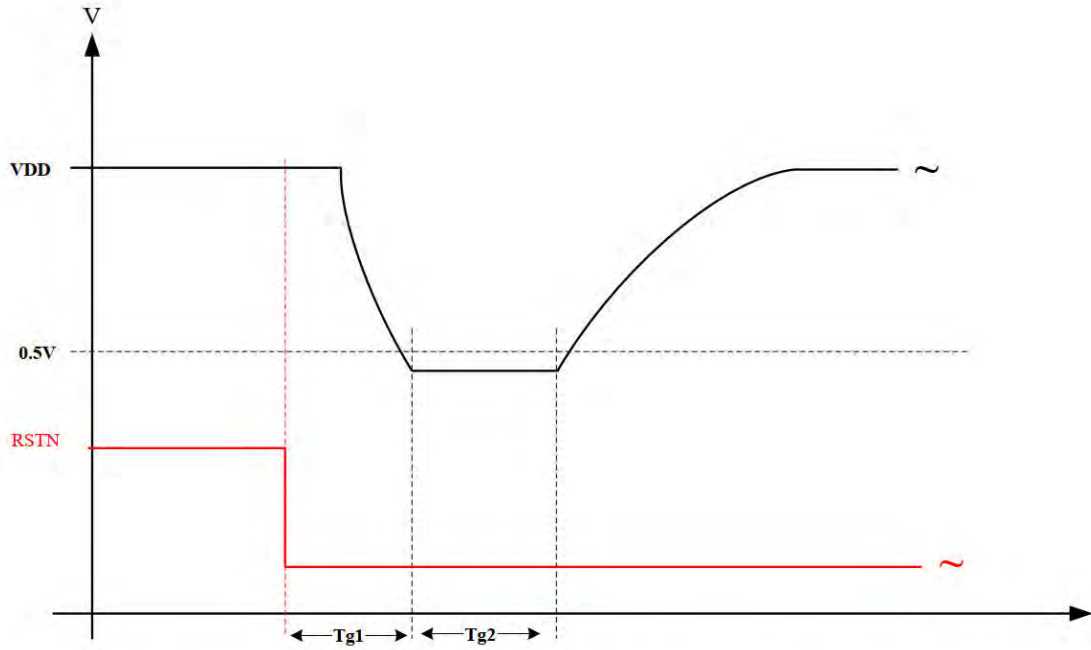

Tg1 : the time difference between power-off and power-on. Tg1 must be $> 10\mu\text{s}$.

Tg2 : the time difference between power-off and power-on. Tg2 must be $> 10\mu\text{s}$.

Note. During the power off time, the VDD must be lower than 0.5V that make sure the touch controller have been correctly reset.

7. Optical Characteristics:

7-1 Overview

The test of Optical specifications shall be measured in a dark room (ambient luminance ≤ 1 lux and temperature = $25 \pm 2^\circ\text{C}$) with the equipment of Luminance meter system (Goniometer system and TOPCONE PR730) and test unit shall be located at an approximate distance 50cm from the LCD surface at a viewing angle of θ and Φ equal to 0° . We refer to $\theta_{\theta=0}$ ($=\theta_3$) as the 3 o'clock direction (the "right"), $\theta_{\theta=90}$ ($=\theta_{12}$) as the 12 o'clock direction ("upward"), $\theta_{\theta=180}$ ($=\theta_9$) as the 9 o'clock direction ("left") and $\theta_{\theta=270}$ ($=\theta_6$) as the 6 o'clock direction ("bottom"). While scanning θ and/or Φ , the center of the measuring spot on the Display surface shall stay fixed. The measurement shall be executed after 30 minutes warm-up period. VDD shall be 5.0V $\pm 10\%$ at 25°C . Optimum viewing angle direction is 6 o'clock.

7-2 Optical Specifications

< Table 5. Module Optical >

Parameter		Symbol	Condition	Min.	Typ.	Max.	Unit	Remark
Viewing Angle range	Horizontal	θ_3	CR > 10	85	89	-	Deg.	Note 1
		θ_9		85	89	-	Deg.	
	Vertical	θ_{12}		85	89	-	Deg.	
		θ_6		85	89	-	Deg.	
Luminance Contrast ratio		CR		700	1000			Note 2
Luminance of White		Y_w		1000	1200	-	cd/m ²	Note 3
White luminance uniformity		ΔY		75	80	-	%	Note 4
Reproduction of color	White	W_x	$\theta = 0^\circ$ (Center) Normal Viewing Angle	0.283	0.313	0.343	-	Note 5
		W_y		0.299	0.329	0.359	-	
	Red	R_x		TBD	TBD	TBD	-	
		R_y		TBD	TBD	TBD	-	
	Green	G_x		TBD	TBD	TBD	-	
		G_y		TBD	TBD	TBD	-	
	Blue	B_x		TBD	TBD	TBD	-	
		B_y		TBD	TBD	TBD	-	
Response Time	GTG	T_g		14	25	ms	Note 6	
Cross Talk		CT		-	-	2.0	%	Note 7

Note :

1. Viewing angle is the angle at which the contrast ratio is greater than 10. The viewing are determined for the horizontal or 3, 9 o'clock direction and the vertical or 6, 12 o'clock direction with respect to the optical axis which is normal to the LCD surface.
2. Contrast measurements shall be made at viewing angle of $\theta=0^\circ$ and at the center of the LCD surface. Luminance shall be measured with all pixels in the view field set first to white, then to the dark (black) state. (See FIGURE 1 shown in Appendix) Luminance Contrast Ratio (CR) is defined mathematically.

$$CR = \frac{\text{Luminance when displaying a white raster}}{\text{Luminance when displaying a black raster}}$$

3. Center Luminance of white is defined as the LCD surface. Luminance shall be measured with all pixels in the view field set first to white. This measurement shall be taken at the locations shown in FIGURE 2 for a total of the measurements per display.
4. The White luminance uniformity on LCD surface is then expressed as :
 $\Delta Y = (\text{Minimum Luminance of 9points} / \text{Maximum Luminance of 9points}) * 100$
 (See FIGURE 2 shown in Appendix).
5. The color chromaticity coordinates specified in Table 5. shall be calculated from the spectral data measured with all pixels first in red, green, blue and white. Measurements shall be made at the center of the panel.
6. Response time Tg is the average time required for display transition by switching the input signal as below table and is based on Frame rate fV =60Hz to optimize. Each time in below table is defined as appendix Figure 3and shall be measured by switching the input signal for “any level of gray(bright)”and “any level of gray(dark)”.

Measured Response Time	Target																
	0	15	31	47	63	79	95	111	127	143	159	175	191	207	223	239	255
0																	
15																	
31																	
47																	
63																	
79																	
95																	
111																	
127																	
143																	
159																	
175																	
191																	
207																	
223																	
239																	
255																	

7. Cross-Talk of one area of the LCD surface by another shall be measured by comparing the luminance (Y_A) of a 25mm diameter area, with all display pixels set to a gray level, to the luminance (Y_B) of that same area when any adjacent area is driven dark. (See FIGURE 4 shown in Appendix).

7-3 Optical Measurements

Figure 1. Measurement Set Up

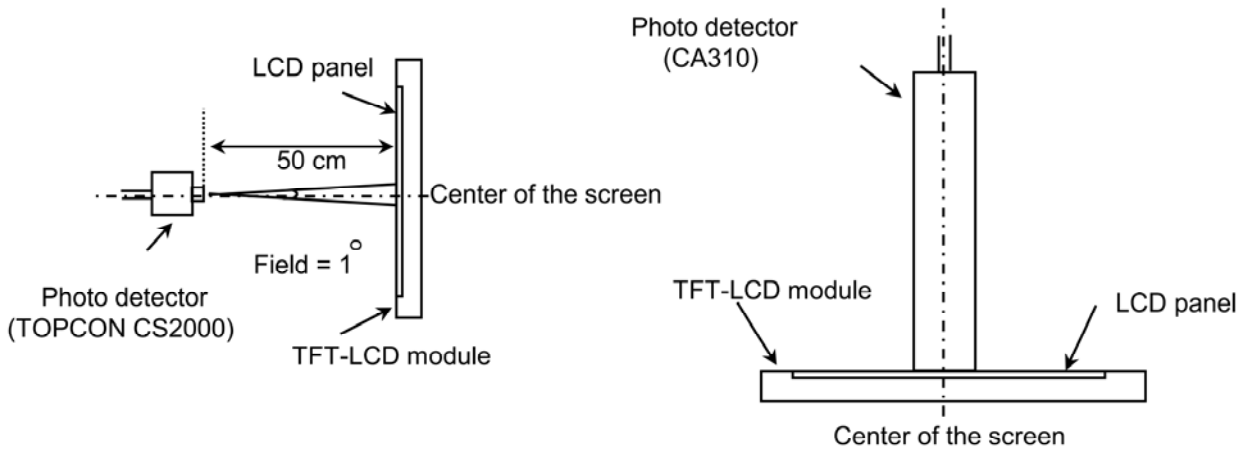

View angel range, uniformity, etc. measurement setup Flicker, measurement setup

Figure 2. White Luminance and Uniformity Measurement Locations (9 points)

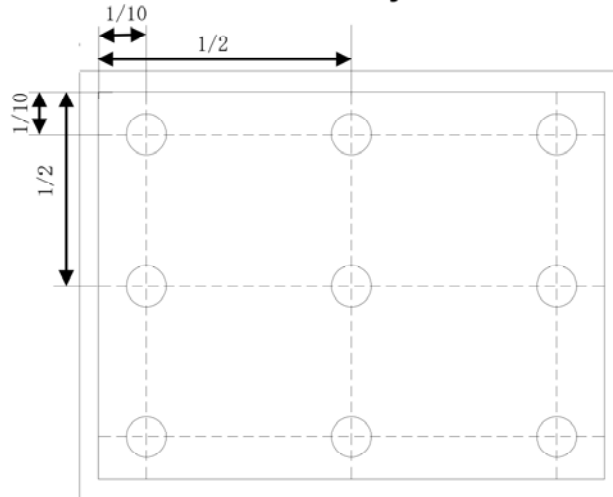

Luminance of white is defined as luminance values of center of the LCD surface. Luminance shall be measured with all pixels in the view field set first to white. This measurement shall be taken at the locations shown in FIGURE 2 for a total of the measurements per display.

The White luminance uniformity on LCD surface is then expressed as : $\Delta Y9 = \text{Minimum Luminance of 9 points} / \text{Maximum Luminance of 9points}$ (see FIGURE 2).

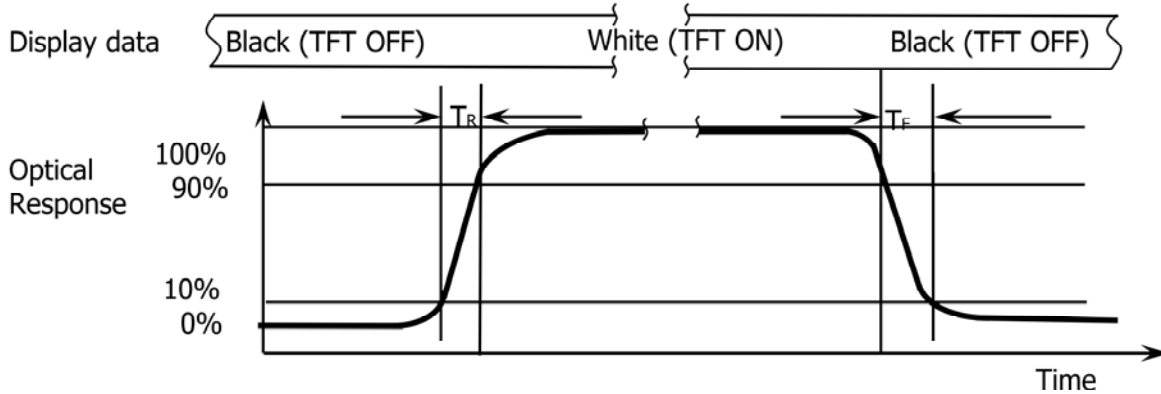
Figure 3. Response Time Testing

The electro-optical response time measurements shall be made as shown in FIGURE 3 by switching the “data” input signal ON and OFF. The times needed for the luminance to change from 10% to 90% is T_r and 90% to 10% is T_d .

8. Interface Pin Assignment:

8-1 TFT Pin Assignment

Pin No	Symbol	Function	Remark
1	RXO0-	Negative Transmission data of Pixel 0 (ODD)	
2	RXO0+	Positive Transmission data of Pixel 0 (ODD)	
3	RXO1-	Negative Transmission data of Pixel 1 (ODD)	
4	RXO1+	Positive Transmission data of Pixel 1 (ODD)	
5	RXO2-	Negative Transmission data of Pixel 2 (ODD)	
6	RXO2+	Positive Transmission data of Pixel 2 (ODD)	
7	GND	Power Ground	
8	RXOC-	Negative Transmission Clock (ODD)	
9	RXOC+	Positive Transmission Clock (ODD)	
10	RXO3-	Negative Transmission data of Pixel 3 (ODD)	
11	RXO3+	Positive Transmission data of Pixel 3 (ODD)	
12	RXE0-	Negative Transmission data of Pixel 0 (EVEN)	
13	RXE0+	Positive Transmission data of Pixel 0 (EVEN)	
14	GND	Power Ground	
15	RXE1-	Negative Transmission data of Pixel 1 (EVEN)	
16	RXE1+	Positive Transmission data of Pixel 1 (EVEN)	
17	GND	Power Ground	
18	RXE2-	Negative Transmission data of Pixel 2 (EVEN)	
19	RXE2+	Positive Transmission data of Pixel 2 (EVEN)	
20	RXEC-	Negative Transmission Clock (EVEN)	
21	RXEC+	Positive Transmission Clock (EVEN)	
22	RXE3-	Negative Transmission data of Pixel 3 (EVEN)	
23	RXE3+	Positive Transmission data of Pixel 3 (EVEN)	
24	GND	Power Ground	Note 1
25	NC	Not connection, this pin should be open	
26	NC	Not connection, this pin should be open	
27	NC	Not connection	
28	VDD	Power Supply: +5V	
29	VDD		
30	VDD		

Note 1 : This pin should be connected with GND.



8-2 TP Pin Assignment

Symbol	Description
P	Power pad
CLK	Clock
I	Input only
O	Output only (Push-pull)
I/O	input / output pad

No.	Name	Type	Description
1	VDD	P	5V input power supply
2	DN	I/O	USB interface
3	DP	I/O	USB interface
4	GND	P	Connect to system ground

9. Block Diagram:

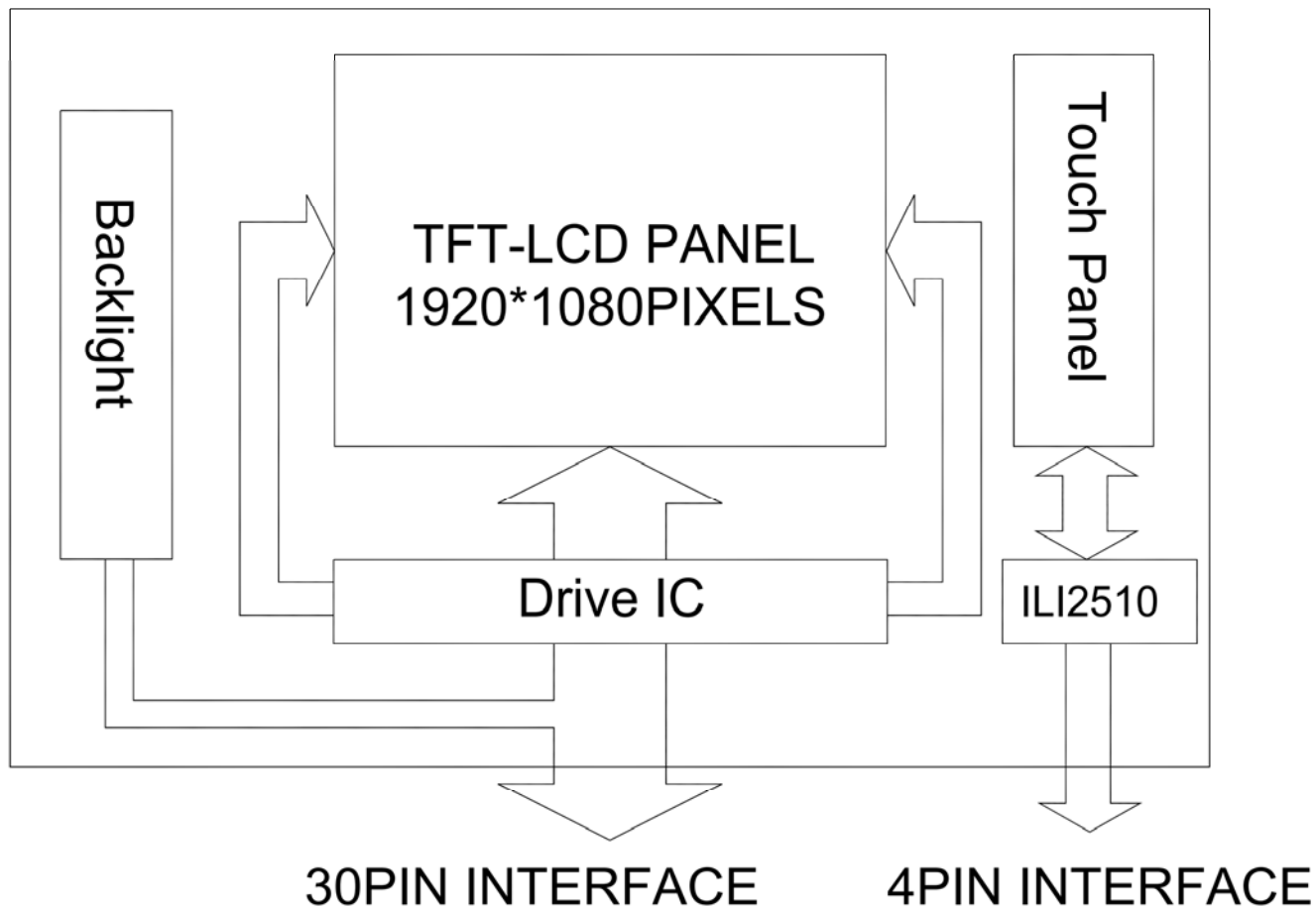



10. Backlight:

Item	Symbol	Min.	TYP.	Max.	Unit	Note
BLU current	I	--	680		mA	
BLU voltage	V		61.6	72.6	V	
BLU Power consumption	P _{BLU}				W	
Operating Lifetime	Hr	30,000	--	--	Hour	68 mA
	Hr	20,000	--	30,000	Hour	80 mA

11. Standard Specification for Reliability :

11-1. Standard Specifications for Reliability

No	Item	Description
01	High temperature operation	The sample should be allowed to stand at 80°C for 240 hours under driving condition and then returning it to normal temperature condition, and allowing it stand for 2 hours.
02	Low temperature operation	The sample should be allowed to stand at -20°C for 240 hours under driving condition and then returning it to normal temperature condition, and allowing it stand for 2 hours.
03	High temperature storage	The sample should be allowed to stand at 85°C for 240 hours under no-load condition, and then returning it to normal temperature condition, and allowing it stand for 2 hours.
04	Low temperature storage	The sample should be allowed to stand at -30°C for 240 hours under no-load condition, then returning it to normal temperature condition, and allowing it stand for 2 hours.
05	Moisture storage	The sample should be allowed to stand at 60°C,90%RH MAX for 240 hours under no-load condition, then taking it out and drying it at normal temperature for 2 hours.
06	Thermal shock storage	-20°C ↔ 60°C (0.5 hr),100 cycle
07	Packing vibration (non-operating)	Frequency Random,10 ~ 300 Hz,30 min/Axis Gravity / AMP 1.05 Grms Period X, Y, Z 30 min
08	Electrical Static Discharge	Air: ±15KV 150pF/330Ω 5 times
		Contact: ±8KV 150pF/330Ω 5 time

11 - 2. Testing Conditions and Inspection Criteria

For the final test the testing sample must be stored at room temperature for 24 hours, after the tests listed in Table 11-1, Standard specifications for Reliability have been executed in order to ensure stability.

No	Item	Test Model	In section Criteria
01	Current Consumption	Refer To Specification	The current consumption should conform to the product specification.
02	Contrast	Refer To Specification	After the tests have been executed, the contrast must be larger than half of its initial value prior to the tests.
03	Appearance	Visual inspection	Defect free.

11- 3. MTBF

MTBF	Functions, performance, appearance, etc. shall be free from remarkable deterioration within 50,000 hours under ordinary operating and storage conditions room temperature ($25\pm 5^{\circ}\text{C}$), normal humidity ($50\pm 10\%$ RH), and in area not exposed to direct sun light.
------	---

12. Specification of Quality Assurance:

12-1. Purpose

This standard for Quality Assurance should affirm the quality of LCD module products to supply to purchaser by YEEBO CORPORATION (Supplier).

12-2. Standard for Quality Test

a. Inspection:

Before delivering, the supplier should take the following tests, and affirm the quality of product.

b. Electro-Optical Characteristics:

According to the individual specification to test the product.

c. Test of Appearance Characteristics:

According to the individual specification to test the product.

d. Test of Reliability Characteristics:

According to the definition of reliability on the specification for testing products.

e. Delivery Test:

Before delivering, the supplier should take the delivery test.

(i) Test method: According to **ISO2859-1**. General Inspection Level II take a single time.

(ii) The defects classify of AQL as following:

Major defect: AQL = 0.65

Minor defect: AQL = 2.5

Total defects: AQL = 2.5

12-3. Non- conforming Analysis & Deal With Manners

a. Non- conforming Analysis:

(i) Purchaser should supply the detail data of non- conforming sample and the non-conforming.

(ii) After accepting the detail data from purchaser, the analysis of non- conforming should be finished in two weeks.

(iii) If supplier can not finish analysis on time, must announce purchaser before 3 days.

b. Disposition of non- conforming:

(i) If find any product defect of supplier during assembly time, supplier must change the good product for every defect after recognition.

(ii) Both supplier and customer should analyze the reason and discuss the disposition of non- conforming when the reason of nonconforming is not sure.

12-4. Agreement items

Both sides should discuss together when the following problems happen.

a. There is any problem of standard of quality assurance, and both sides should think that must be modified.

b. There is any argument item which does not record in the standard of quality assurance.

c. Any other special problem.

12-5. Standard of The Product Appearance Test

a. Manner of appearance test:

- (i) The test must be under $20W \times 2$ or $40W$ fluorescent light, and the distance of view must be at 30 ± 5 cm.
- (ii) When test the model of transmissive product must add the reflective plate.
- (iii) The test direction is base on around 10° of vertical line.
- (iiii) Temperature: $25 \pm 5^\circ C$ Humidity: $60 \pm 10\% RH$

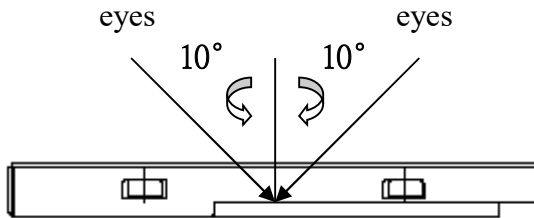

(iv) Definition of area:

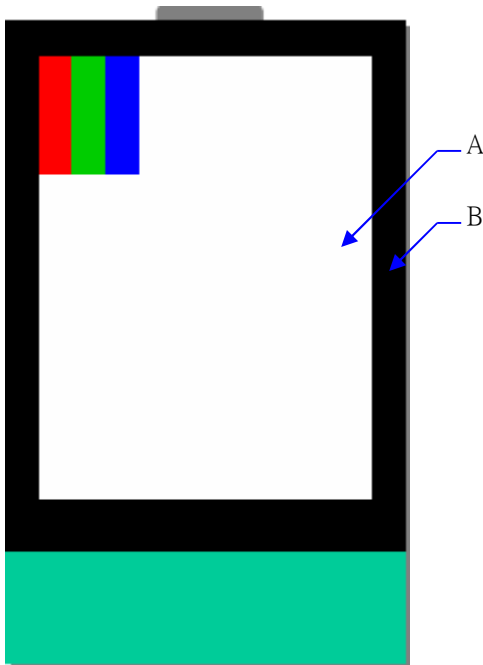

- A. Area: Viewing area.
- B. Area: Out of viewing area.
(Outside viewing area)

b. Basic principle:

- (i) It will accord to the AQL when the standard can not be described.
- (ii) The sample of the lowest acceptable quality level must be discussed by both supplier and customer when any dispute happened.
- (iii) Must add new item on time when it is necessary.

c. Standard of inspection: (Unit: mm)

12-6. Inspection specification
Defect out of viewing area can be neglected.

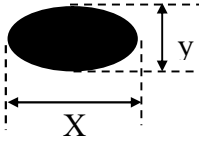
Item	Specification	Unit : mm	AQL												
Electrical Testing	1.1 Open 1.2 Short 1.3 T/P failure 1.4 Missing vertical, horizontal segment, segment contrast defect. 1.5 Missing character, dot or icon. 1.6 Display malfunction. 1.7 No function or no display. 1.8 Current consumption exceeds product specifications. 1.9 LCD viewing angle defect. 1.10 Mixed product types. 1.11 Flicker		0.65												
explosion-proof film bubble/Concave and convex point/indentation / Contamination	<table border="1" style="margin-bottom: 10px;"> <thead> <tr> <th>D</th> <th>Acceptable numbers</th> </tr> </thead> <tbody> <tr> <td>≤ 0.3</td> <td>ignored (No more than five spots within 5mm G)</td> </tr> <tr> <td>$0.3 < D \leq 0.5$</td> <td>4</td> </tr> <tr> <td>$0.5 < D \leq 1.0$</td> <td>2</td> </tr> <tr> <td>$1.0 < D \leq 1.5$</td> <td>2</td> </tr> <tr> <td>$D > 1.5$</td> <td>NG</td> </tr> </tbody> </table> <div style="display: flex; align-items: center; justify-content: center;">  <div style="margin-left: 20px;"> $D = (x+y) / 2$ </div> </div> <ol style="list-style-type: none"> 1、 Product's front side checked according to this specification, back side ignored, but light leakage is not allowed. 2、 Printing ink peel off is not allowed. 3、 The particle will be ignored when it is removable by cleaning <p>* Densely spaced: No more than two spots within 10mm</p>	D	Acceptable numbers	≤ 0.3	ignored (No more than five spots within 5mm G)	$0.3 < D \leq 0.5$	4	$0.5 < D \leq 1.0$	2	$1.0 < D \leq 1.5$	2	$D > 1.5$	NG		2.5
D	Acceptable numbers														
≤ 0.3	ignored (No more than five spots within 5mm G)														
$0.3 < D \leq 0.5$	4														
$0.5 < D \leq 1.0$	2														
$1.0 < D \leq 1.5$	2														
$D > 1.5$	NG														

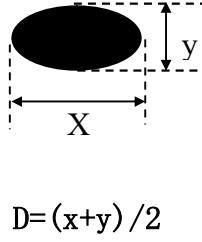
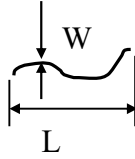
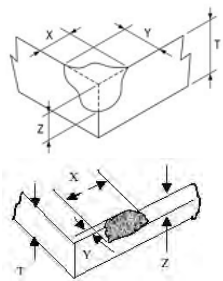
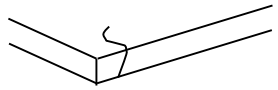
Black spots / White spots /Bright spots/ Color spots /polluted inside/ punctured	D		Acceptable numbers		2.5
	≤ 0.2		ignored (No more than five spots within 5mm)		
	$0.2 < D \leq 0.4$		4		
	$0.4 < D \leq 0.8$		3		
Linear Object: Fiber, scurf, scratches and other linear defects (not affecting function)	W	L	Acceptable numbers		2.5
	≤ 0.05	≤ 8	ignored No more than five lines within 5mm)		
	$0.1 < W \leq 0.3$	≤ 8	2		
	$W > 0.3$		NG		
Glass edge chipping、edge breakage	Edge breakage can't affect visual effect (edge breakage can't cause damage to circuit); over lens have no visual damage			2.5	
	conditions				Acceptable numbers
	$X \leq 3mm, Y \leq 2mm, Z \leq T$				5
Glass broken	Visual broken is NG, and there is no potential fault.				0.65

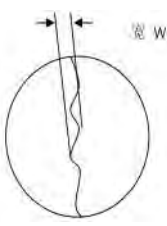
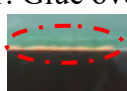
1. V/A printed edges sawtooth inspected according to this standard 2. LOGO's sawtooth	Some contentious defect judged according to samples			2.5
	Product type	Conditions		
	Same size	1、 width below 0.2 inch (included) ignored, above 0.2 NG 2、 Length not accounted		
Specific dimension	In accordance with product outline drawing or specification (key dimension) or engineering sample.			2.5
Glue overflow/Frame	1. Glue overflow exceed 0.2mm to the black frame is not allowed. 			2.5
FPC	Bonding bubble/ Misalignment	FPC golden finger hot pressure's bubble or impurity diameter shall be below 1/2 of the pressed area, pressed deviation shall not exceed 1/2 of the silver line width, and 40X microscope cannot have obvious cracks.		0.65
	Folded mark (minor fault)	Linearity irreversibility folded mark and acute angle folded mark is NG.		2.5
	EMI FILM (minor fault)	Surface broken, scratched $\leq 0.3\text{mm}$ Surface broken below 5mm can be modified by print ink, after modified, the result shall be achieved to EMI		2.5

13. Handling Precaution:

13-1 Handling of LCM

- Don't give external shock.
- Don't apply excessive force on the surface.
- Liquid in LCD is hazardous substance. Must not lick and swallow. when the liquid is attach to your hand, skin, cloth etc. Wash it out thoroughly and immediately.
- Don't operate it above the absolute maximum rating.
- Don't disassemble the LCM.
- The operators should be grounded whenever he/she comes into contact with the module. Never touch any of the conductive parts such as the LSI pads, the copper leads on the PCB and the interface terminals with any parts of the human body.
- The modules should be kept in antistatic bags or other containers resistant to static for storage.
- The module is coated with a film to protect the display surface. Be care when peeling off this protective film since static electricity may be generated.

13-2 Storage

- Store in an ambient temperature of $25\pm 10^{\circ}\text{C}$, and in a relative humidity of $50\pm 10\%\text{RH}$. Don't expose to sunlight or fluorescent light.
- Storage in a clean environment, free from dust, active gas, and solvent.
- Store in anti-static electricity container.
- Store without any physical load.

13-3 Soldering

- Use only soldering irons with proper grounding and no leakage.
- Iron: No higher than $310\pm 10^{\circ}\text{C}$ and less than 3 sec during Hand soldering.
- Rewiring: no more than 2 times.



14. Warranty

This product has been manufactured to specifications as a part for use in your company's general electronic products. It is guaranteed to perform according to delivery specifications. For any other use apart from general electronic equipment, we will not take responsibility if the product is used in medical devices, nuclear power control equipment, aerospace equipment, fire and security systems, or any other applications in which there is a direct risk to human life and where extremely high levels of reliability are required. If the product is to be used in any of the above applications, we will need to enter into a separate product liability agreement.

1. We cannot accept responsibility for any defect arise after additional process of the product (including disassembly and reassembly), after product delivery.
2. We cannot accept responsibility for any defect, which may arise after the application of strong external force to the product.
3. We cannot accept responsibility for any defect, which may arise due to the application of static electricity after the product has passed your company's acceptance inspection procedures.
4. We can not accept responsibility for industrial property, which may arise through the use of your product , with exception to those issues relating directly to the structure or method of manufacturing of our product within one year from YEEBO shipment.
5. For Heatseal Product which required to heatseal by customer side, parts must be used within three months after delivery from factory.
6. For TAB Product which required to solder by customer side, parts must be used within three months after delivery from factory.
7. The liability of YB is limited to repair or replacement on the terms set forth below. YB will not be responsible for any subsequent or consequential events or injury or damage to any personnel or user including third party personnel and/or user. Unless otherwise agreed in writing between YB and the customer, YB will only replace or repair any of its LCD which is found defective electrically or visually when inspected in accordance with YB GENERAL LCD INSPECTION STANDARD.

15. Guarantee:

Our products meet requirements of the environment.
YEEBO ROHS requirement is based on European Union Directive 2011/65/EU(ROHS)
Requirements and Update.