



# SPECIFICATION FOR LCD MODULE

MODULE NO: YB-TG320480S07A-C-A0

Doc.Version:01

Customer Approval:

<input type="checkbox"/> Accept	<input type="checkbox"/> Reject
---------------------------------	---------------------------------

YEEBO	NAME	SIGNATURE	DATE
Prepare	Electronic Engineer	傅國長	2018/01/29
Check	Mechanical Engineer	林西茗	2018/01/29
Verify		蔡志勤	2018/01/29
Approval		何不益	2018/1/30

APPROVAL FOR SPECIFICATIONS ONLY

APPROVAL FOR SPECIFICATIONS AND SAMPLE

WIMRD005-02-D



### 1. Revision History

Sample Version	DOC. Version	DATE	DESCRIPTION		CHANGED BY
A0	00	2017-03-22	SPEC ONLY	First issue	Gavin/Fen.
A0	01	2018-01-29	FULL SPEC	First Sample	Gavin/Fen.



**2. Table of Contents:**

NO	CONTENTS	PAGE
1	Revision History	1
2	Table of Contents	2
3	Module Numbering System	3
4	General Specification	4
5	LCM drawing	5
6	Electrical Characteristics	6
7	Optical Characteristics	13
8	Interface Pin Assignment	15
9	Block Diagram	18
10	Backlight	19
11	Standard Specification for Reliability	20
12	Specification of Quality Assurance	22
13	Handing Precaution	30
14	Guarantee	30



### 3. Module Numbering System:

(Example)

**YB-TG240320S01D-T-A0**

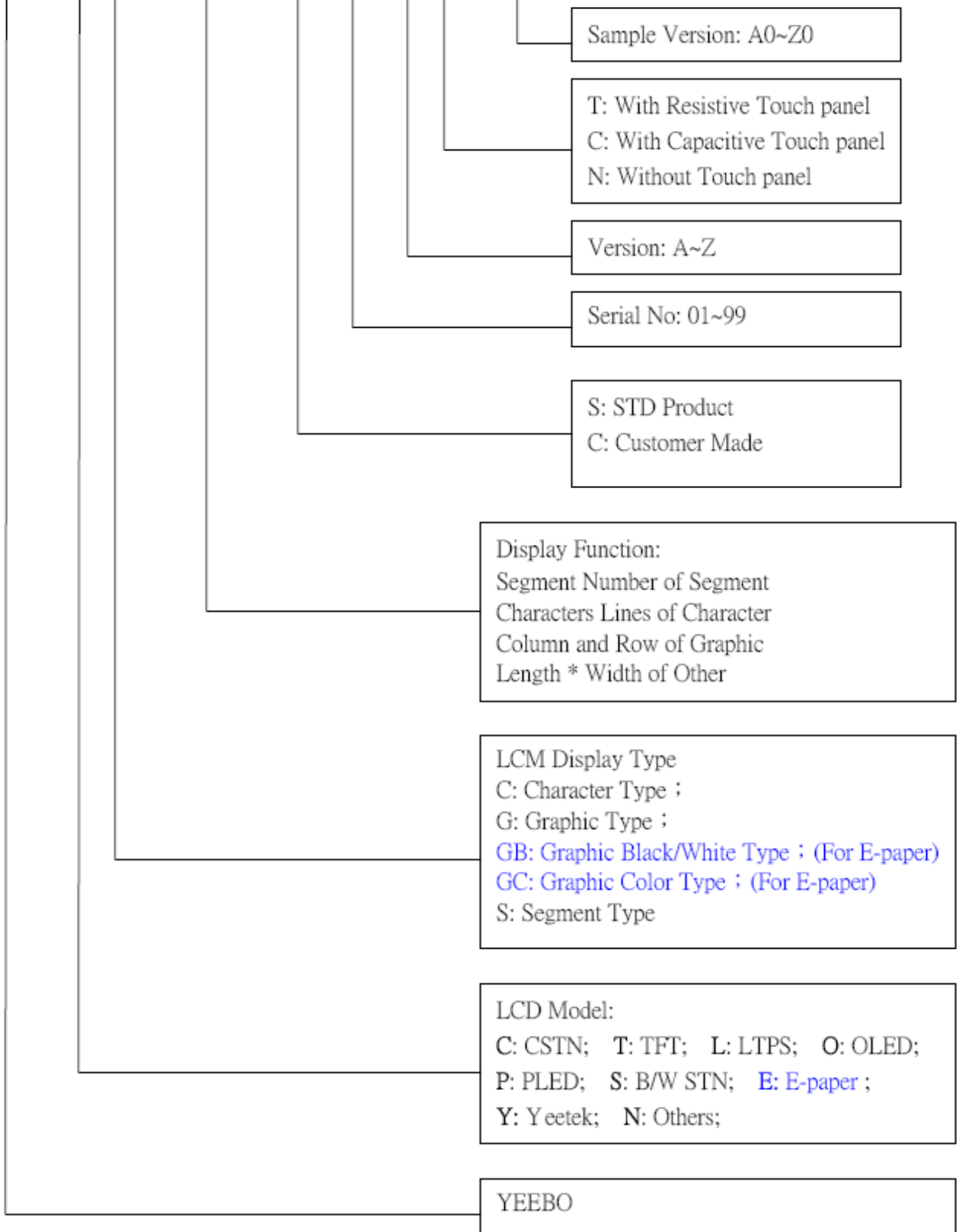

#### **4. General Specification:**

ITEM	CONTENTS
Module Size	63.2(W) * 94.5(H) * 3.6(T) mm
Module Size(With FPC)	63.2(W) * 127.85(H) * 3.6(T) mm
Display Size(Diagonal)	3.5 inch
Display Format	320(RGB) * 480 Pixels
Active Area	48.96(W) * 73.44(H) mm
Pixel Pitch	0.153 * 0.153 mm
LCD Type	TFT(262K) / Transmissive/ NW
View Direction (Gray Inversion)	12:00 O'clock
The Best Viewing Direction:	6:00 O'clock
Controller IC	ST7796S
CTP IC	ST1624
Weight	31.4g

### 5. LCM drawing:

Rec:	Count drawing & Spec:revision record during discussion with customer	Date
#1	Revision content description	2017-03-22
	FRST ISSUE	

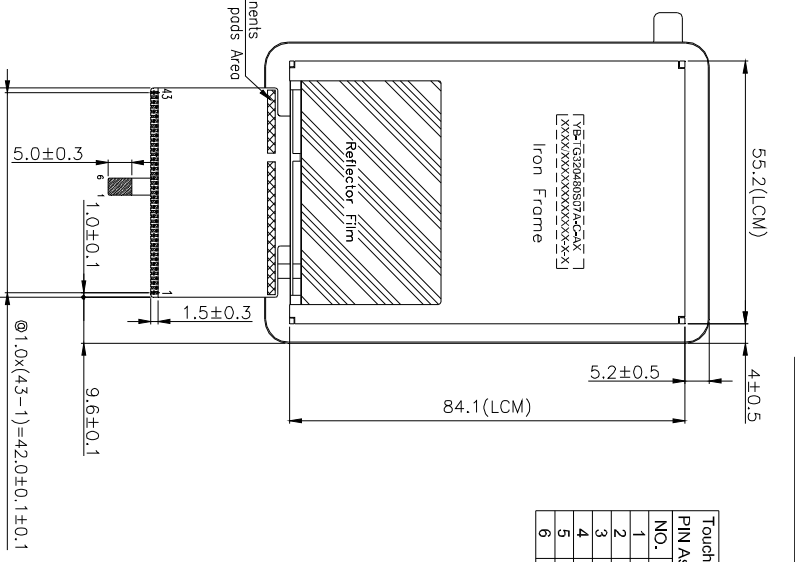
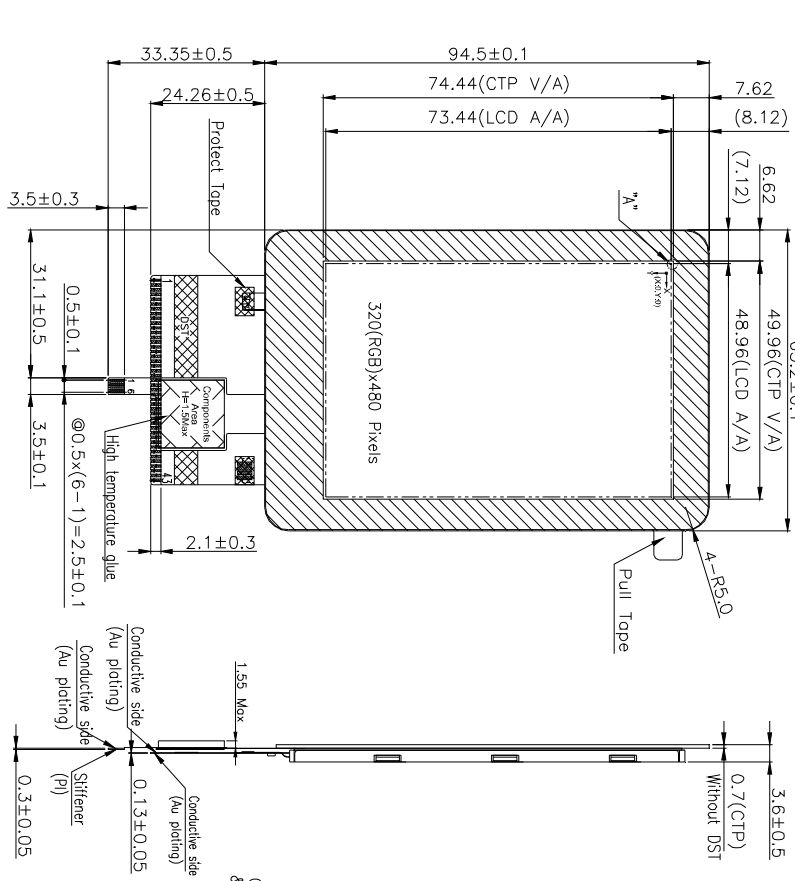

**Specification:**

1. Display mode: 3.5" TFT (262K) / Normal White / Transmissive
2. Viewing direction: Gray Inversion direction: 12 O'clock  
The Best Viewing Direction: 6 O'clock
3. Operating temperature: -20°C to +70°C  
Storage temperature: -30°C to +80°C
4. Drive ICs: S17796S or compatible
5. Backlight: 6 CHIP WHITE LED
6. Unspecified tolerance: ±0.30mm.
7. ROHS compliant
8. Glass Type: OGS
9. Channel NO.: 12(TX) x 9(RX)
10. CTP Drive IC: ST1624

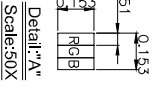

CIRCUIT DIAGRAM  
B/L Electrical Circuit



YB-TG320480S07A-C-AX — Yeebo P/N.  
XXXXXXXXXXXXXXXXXXXX-K-X  
LOT NO.  
Production Year and week

Touch Panel PIN Assignment NO.	SYMBOL	FPC PIN OUT NO.	SYMBOL
1	VDD	1	GND
2	RESET	2	LED-(K)
3	INT	3	LED-(A)
4	SCL	4	VDDA
5	SDA	5	VDDI
6	GND	6	TE
7		7	CSX
8		8	DCX(RS)
9		9	WRX(SCL)
10		10	RDX
11		11	SDA
12		12	DDUT(SDO)
13		13	DB0
14		14	DB1
15		15	DB2
16		16	DB3
17		17	DB4
18		18	DB5
19		19	DB6
20		20	DB7
21		21	DB8
22		22	DB9
23		23	DB10
24		24	DB11
25		25	DB12
26		26	DB13
27		27	DB14
28		28	DB15
29		29	DB16
30		30	DB17
31		31	ENABLE
32		32	DOTCLK
33		33	HSYNC
34		34	VSYNC
35		35	RESET
36		36	IM2
37		37	IM1
38		38	IM0
39		39	GND
40		40	NC(YU)
41		41	NC(XL)
42		42	NC(YD)
43		43	NC(XR)

<b>YEEBO</b>		MOD. Name	YB-TG320480S07A-C-A	DESIGNED	CHECKED	VERIFIED	APPROVED	FILE NAME
UNIT	SIZE	SCALE	林麗芬	2017-03-22				Count Dwg.
mm	A4	N-T-S						
Sheet	1	Of	1					

## 6. Electrical Characteristics

### 6-1 Absolute Maximum Ratings

(Ta=25°C VSS=0V)

Item	Symbol	Min.	Type	Max.	Unit	Remark
Supply Voltage(Analog)	VDDA	-0.3	-	+4.6	V	Note1
Supply Voltage(Logic)	VDDI	-0.3		+4.6		Note1
Logic Input Voltage Range	VIN	0.5		VDDI+0.5	V	Note1
Operating Temperature	Topr	-20	-	+70	°C	-
Storage Temperature	Tstg	-30	-	+80	°C	-

Note1: Absolute maximum rating is the limit value beyond which the IC maybe broken.  
They do not assure operations.

### 6-2 Operating Conditions

(Ta=25°C )

Item	Symbol	Condition	Min.	Typ.	Max.	Unit
Power Supply voltage	VDDA&VDDI	-	2.6	2.8	3.0	Volt
Input Voltage	V <sub>IH</sub>	-	0.7 * VDDI	-	VDDI	V
	V <sub>IL</sub>	-	VSS	-	0.3* VDDI	V
Power Supply Current for LCM	IDD	VDD=2.8V	-	17	25.5	mA

### Touch panel controller ST1624

Item	Symbol	Min.	Typ.	Max.	Unit
Power Supply	VDD	2.7	2.8	3.6	Volt

### 6-3 Timing Characteristics

#### 8080 Series MCU Parallel interface Characteristics: 18/16/9/8-bit Bus

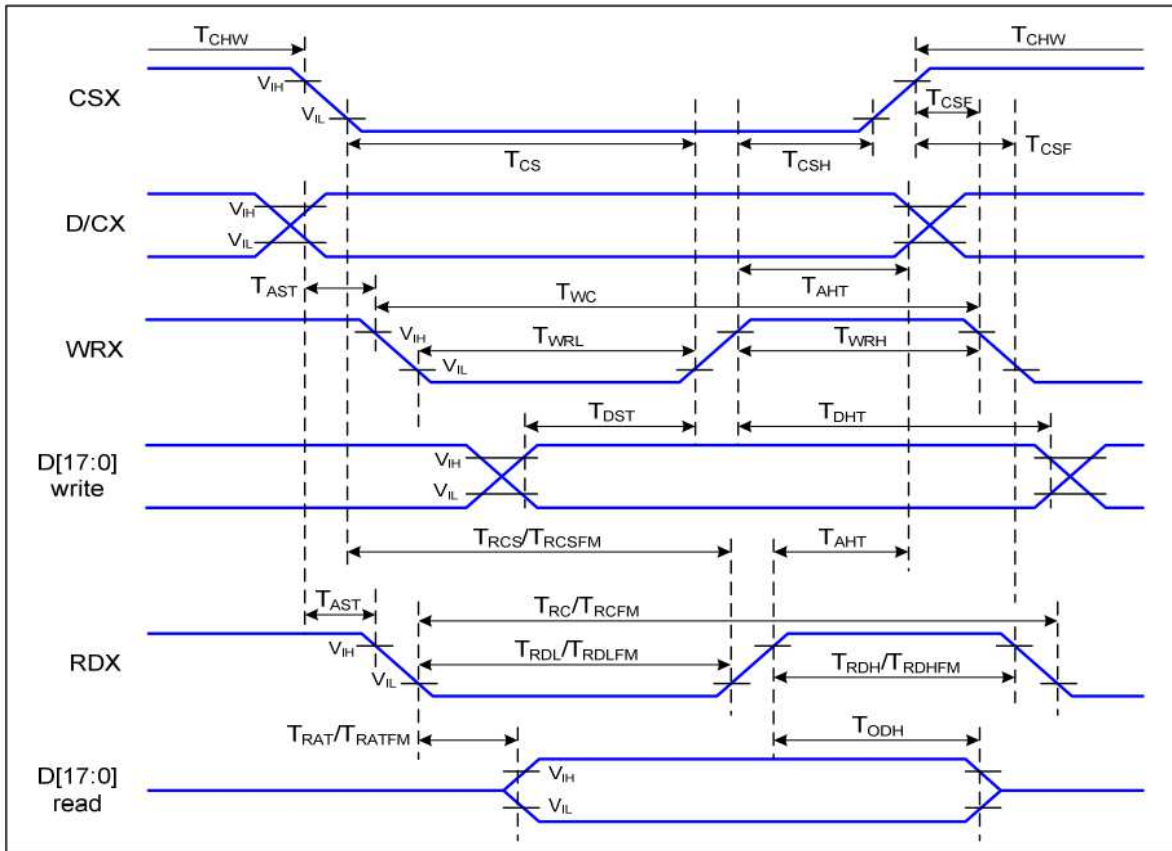

Parallel Interface Timing Characteristics (8080-Series MCU Interface)

VDDI=1.8V, VDVA=2.8V, AGND=DGND=0V, Ta=25 °C

Signal	Symbol	Parameter	Min	Max	Unit	Description
D/CX	$T_{AST}$	Address setup time	0		ns	-
	$T_{AHT}$	Address hold time (Write/Read)	10		ns	
CSX	$T_{CHW}$	Chip select "H" pulse width	0		ns	-
	$T_{CS}$	Chip select setup time (Write)	15		ns	
	$T_{RCS}$	Chip select setup time (Read ID)	45		ns	
	$T_{RCSFM}$	Chip select setup time (Read FM)	355		ns	
	$T_{CSF}$	Chip select wait time (Write/Read)	10		ns	
	$T_{CSH}$	Chip select hold time	10		ns	
WRX	$T_{WC}$	Write cycle	66		ns	-
	$T_{WRH}$	Control pulse "H" duration	15		ns	



	$T_{WRL}$	Control pulse "L" duration	15		ns	
RDX (ID)	$T_{RC}$	Read cycle (ID)	160		ns	When read ID data
	$T_{RDH}$	Control pulse "H" duration (ID)	90		ns	
	$T_{RDL}$	Control pulse "L" duration (ID)	45		ns	
RDX (FM)	$T_{RCFM}$	Read cycle (FM)	450		ns	When read from frame memory
	$T_{RDHFM}$	Control pulse "H" duration (FM)	90		ns	
	$T_{RDLFM}$	Control pulse "L" duration (FM)	355		ns	
D[17:0]	$T_{DST}$	Data setup time	10		ns	For CL=30pF
	$T_{DHT}$	Data hold time	10		ns	
	$T_{RAT}$	Read access time (ID)	-	40	ns	
	$T_{RATFM}$	Read access time (FM)	-	340	ns	
	$T_{ODH}$	Output disable time	20	80	ns	

8080 Parallel Interface Characteristics

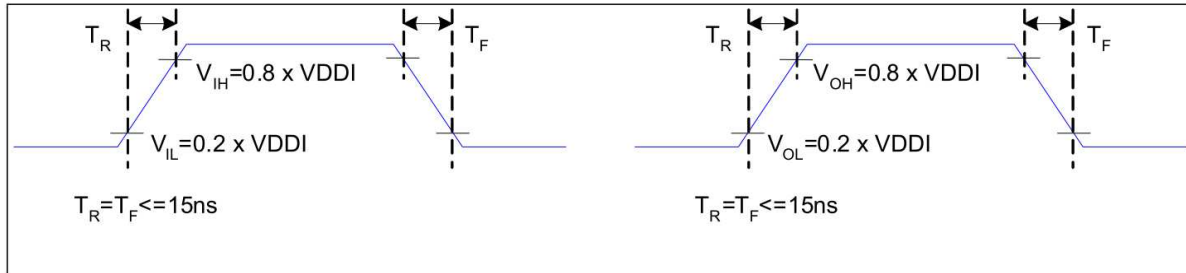

Rising and Falling Timing for I/O Signal

Note: The rising time and falling time ( $T_r$ ,  $T_f$ ) of input signal and fall time are specified at 15 ns or less. Logic high and low levels are specified as 20% and 80% of  $V_{DDI}$  for Input signals.

3-SPI Serial Data Transfer Interface Characteristics:

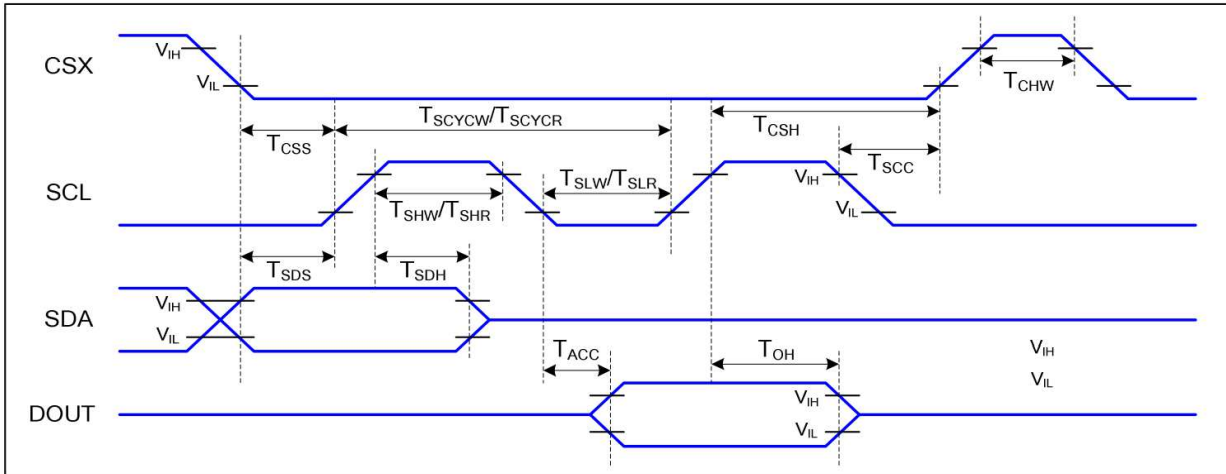

3-SPI Interface Timing Characteristics

VDDI=1.8V, VDDA=2.8V, AGND=DGND=0V, Ta=25 °C

Signal	Symbol	Parameter	Min	Max	Unit	Description
CSX	T <sub>CSS</sub>	Chip select setup time (write)	15		ns	
	T <sub>CSH</sub>	Chip select hold time (write)	15		ns	
	T <sub>CSS</sub>	Chip select setup time (read)	60		ns	
	T <sub>SCC</sub>	Chip select hold time (read)	65		ns	
	T <sub>CHW</sub>	Chip select "H" pulse width	40		ns	
SCL	T <sub>SCYCW</sub>	Serial clock cycle (Write)	66		ns	
	T <sub>SHW</sub>	SCL "H" pulse width (Write)	15		ns	
	T <sub>SLW</sub>	SCL "L" pulse width (Write)	15		ns	
	T <sub>SCYCR</sub>	Serial clock cycle (Read)	150		ns	
	T <sub>SHR</sub>	SCL "H" pulse width (Read)	60		ns	
	T <sub>SLR</sub>	SCL "L" pulse width (Read)	60		ns	
SDA (DIN)	T <sub>SDS</sub>	Data setup time	10		ns	
	T <sub>SDH</sub>	Data hold time	10		ns	
DOUT	T <sub>ACC</sub>	Access time	10	50	ns	For maximum CL=30pF
	T <sub>OH</sub>	Output disable time	15	50	ns	For minimum CL=8pF

3-SPI Interface Characteristics

### 4-SPI Serial Data Transfer Interface Characteristics

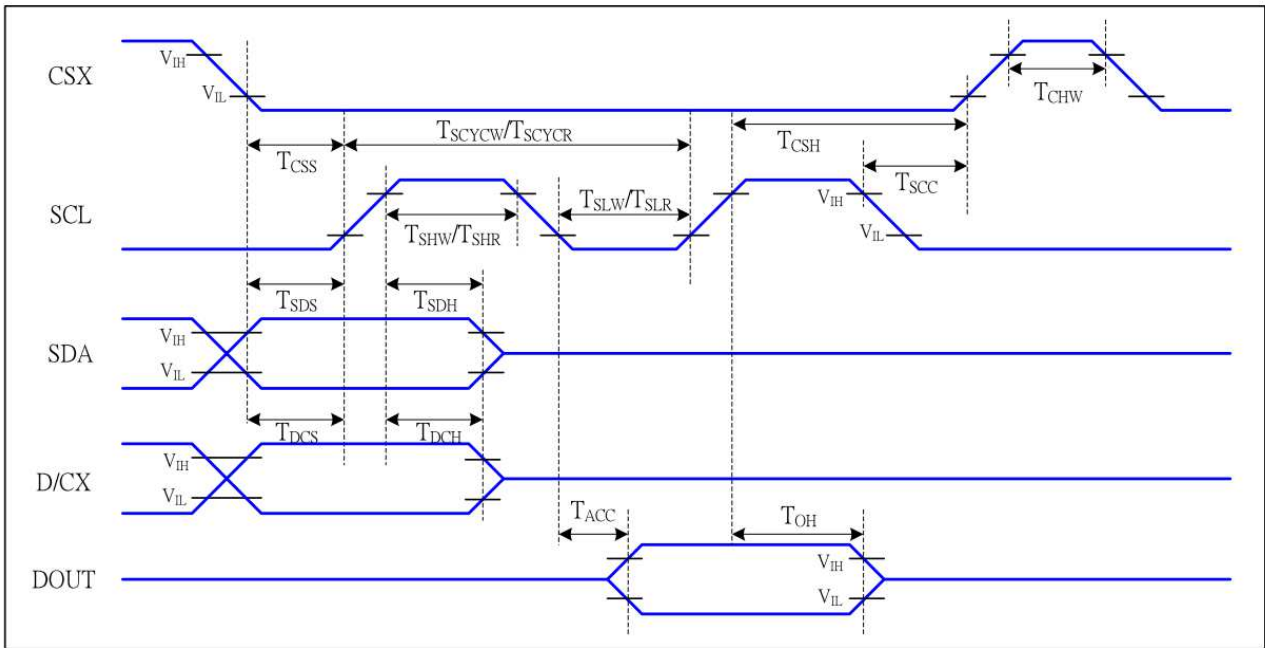

4-SPI Interface Timing Characteristics

VDDI=1.8V, VDDA=2.8V, AGND=DGND=0V, Ta=25 °C

Signal	Symbol	Parameter	MIN	MAX	Unit	Description
CSX	T <sub>CSS</sub>	Chip select setup time (write)	15		ns	
	T <sub>CSH</sub>	Chip select hold time (write)	15		ns	
	T <sub>CSS</sub>	Chip select setup time (read)	60		ns	
	T <sub>SCC</sub>	Chip select hold time (read)	65		ns	
	T <sub>CHW</sub>	Chip select "H" pulse width	40		ns	
SCL	T <sub>SCYCW</sub>	Serial clock cycle (Write)	66		ns	-write command & data ram
	T <sub>SHW</sub>	SCL "H" pulse width (Write)	15		ns	
	T <sub>SLW</sub>	SCL "L" pulse width (Write)	15		ns	
	T <sub>SCYCR</sub>	Serial clock cycle (Read)	150		ns	-read command & data ram
	T <sub>SHR</sub>	SCL "H" pulse width (Read)	60		ns	
	T <sub>SLR</sub>	SCL "L" pulse width (Read)	60		ns	
D/CX	T <sub>DCS</sub>	D/CX setup time	10		ns	
	T <sub>DCH</sub>	D/CX hold time	10		ns	
SDA (DIN)	T <sub>SDS</sub>	Data setup time	10		ns	
	T <sub>SDH</sub>	Data hold time	10		ns	
DOUT	T <sub>ACC</sub>	Access time	10	50	ns	For maximum CL=30pF
	T <sub>OH</sub>	Output disable time	15	50	ns	For minimum CL=8pF

RGB Interface Characteristics:

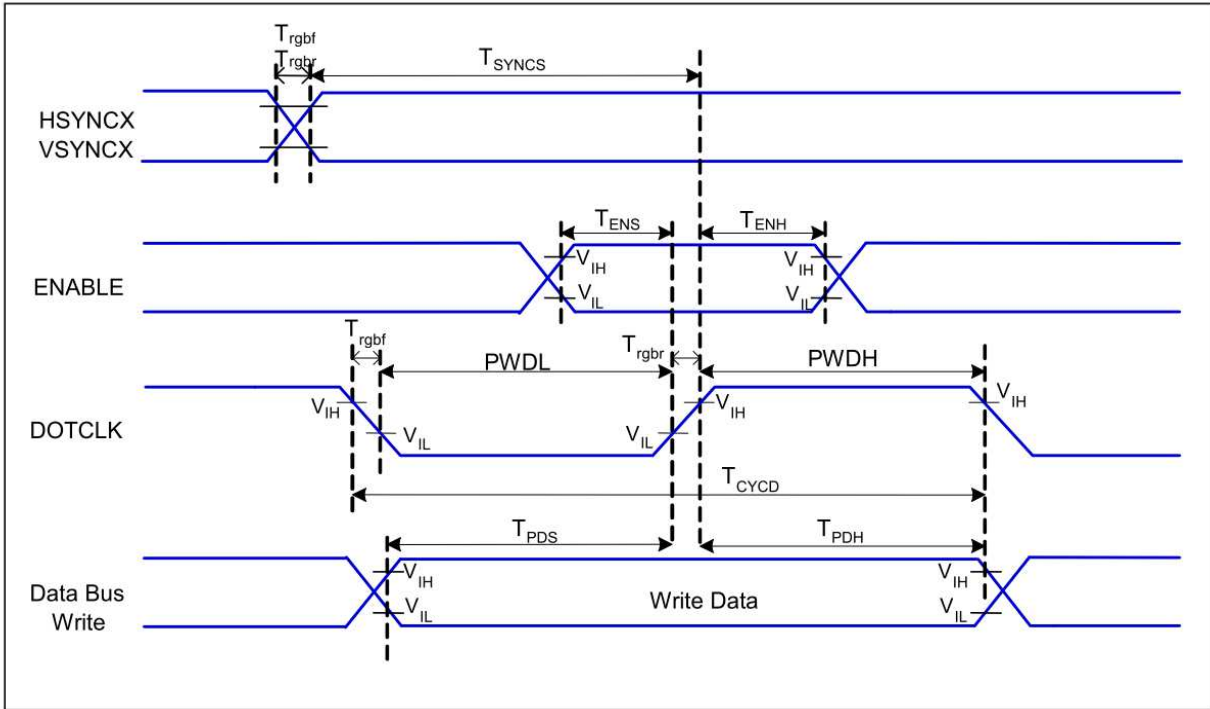

VDDI=1.8V, VDDA=2.8V, AGND=DGND=0V, Ta=25°C

Signal	Symbol	Parameter	MIN	MAX	Unit	Description
HSYNC, VSYNC	$T_{SYNCS}$	VSYNC, HSYNC Setup Time	15	-	ns	
ENABLE	$T_{ENS}$	Enable Setup Time	15	-	ns	
	$T_{ENH}$	Enable Hold Time	15	-	ns	
DOTCLK	PWDH	DOTCLK High-level Pulse Width	30	-	ns	
	PWDL	DOTCLK Low-level Pulse Width	30	-	ns	
	$T_{CYCD}$	DOTCLK Cycle Time	66	-	ns	
	Trghr, Trghf	DOTCLK Rise/Fall time	-	15	ns	
DB	$T_{PDS}$	PD Data Setup Time	15	-	ns	
	$T_{PDH}$	PD Data Hold Time	15	-	ns	

RGB Interface Timing Characteristics

Touch panel controller ST1624

I2C Interface

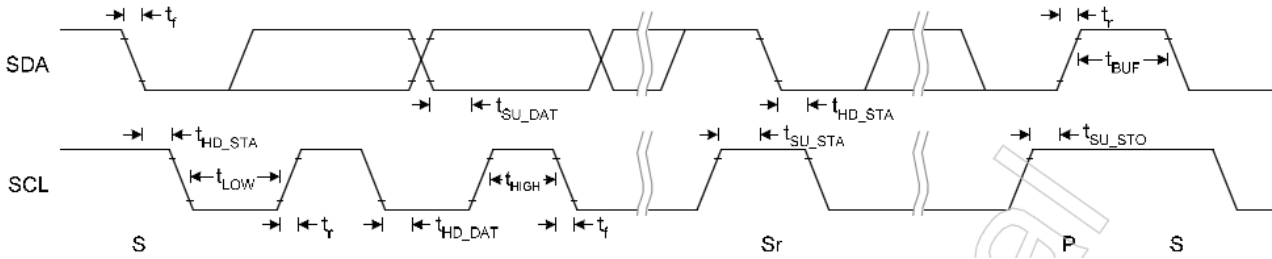

Symbol	Parameter	Rating			Unit
		Min.	Typ.	Max.	
$f_{SCL}$	SCL clock frequency	0	-	400	kHz
$t_{LOW}$	Low period of the SCL clock	1.3	-	-	us
$t_{HIGH}$	High period of the SCL clock	0.6	-	-	us
$t_f$	Signal falling time	-	-	300	ns
$t_r$	Signal rising time	-	-	300	ns
$t_{SU\_STA}$	Set up time for a repeated START condition	0.6	-	-	us
$t_{HD\_STA}$	Hold time (repeated) START condition. After this period, the first clock pulse is generated	0.6	-	-	us
$t_{SU\_DAT}$	Data set up time	100	-	-	ns
$t_{HD\_DAT}$	Data hold time	0	-	0.9	us
$t_{SU\_STO}$	Set up time for STOP condition	0.6	-	-	us
$t_{BUF}$	Bus free time between a STOP and START condition	1.3	-	-	us
$C_b$	Capacitive load for each bus line	-	-	400	pF



## 7. Optical Characteristics:

Item	Symbol	Conditions	Specifications			Unit	Note	
			Min	Typ	Max			
Transmittance (With PL)	T(%)	-	-	5.5	-	-	-	
Contrast Ratio	CR	$\Theta = 0$ Normal Viewing angle	-	500	-		(1) (2)	
Response time	TR+TF	-	-	16	-	ms	(1) (3)	
Viewing angle	Hor.	$\Theta_{x+}$	CR $\geq 10$	-	70	-	deg.	-
		$\Theta_{x-}$		-	70	-		
	Ver.	$\Theta_{y+}$		-	70	-		
		$\Theta_{y-}$		-	60	-		

### Measuring Condition

1. Measuring surrounding: dark room
2. Ambient temperature:  $25 \pm 2^\circ\text{C}$
3. 30 min. Warm-up time.

### Color of CIE Coordinate:

Item		Symbol	Condition	Min.	Typ.	Max.
Chromaticity Coordinates (Transmissive)	Red	x	$\theta = \phi = 0^\circ$ LED Backlight	0.548	0.598	0.648
		y		0.304	0.354	0.404
	Green	x		0.268	0.318	0.368
		y		0.561	0.611	0.661
	Blue	x		0.097	0.147	0.197
		y		0.050	0.100	0.150
	White	x		0.248	0.298	0.348
		y		0.292	0.342	0.392

Note (1) Definition of Viewing Angle :

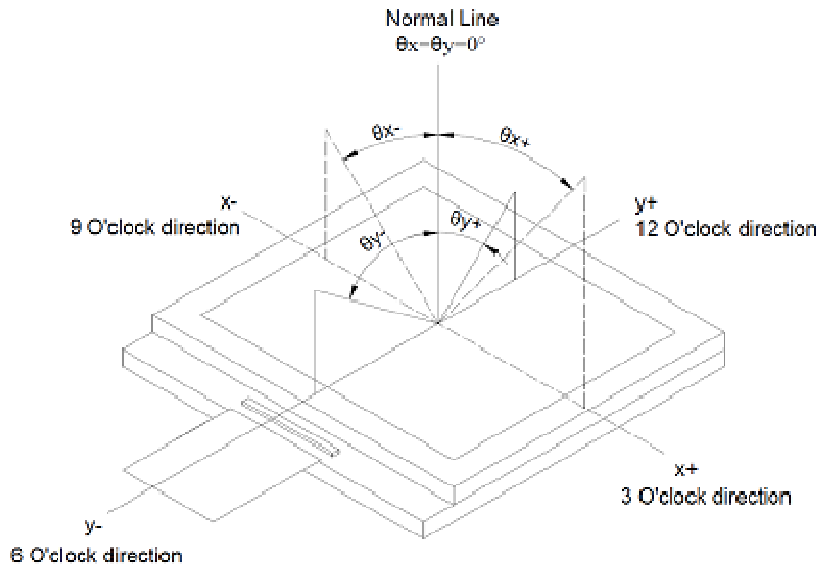

Note (2) Definition of Contrast Ratio(CR) :  
measured at the center point of panel

$$\text{Contrast ratio (CR)} = \frac{\text{Photo detector output when LCD is at "White" state}}{\text{Photo detector output when LCD is at "Black" state}}$$

Note (3) Definition of Response Time : Sum of TR and TF

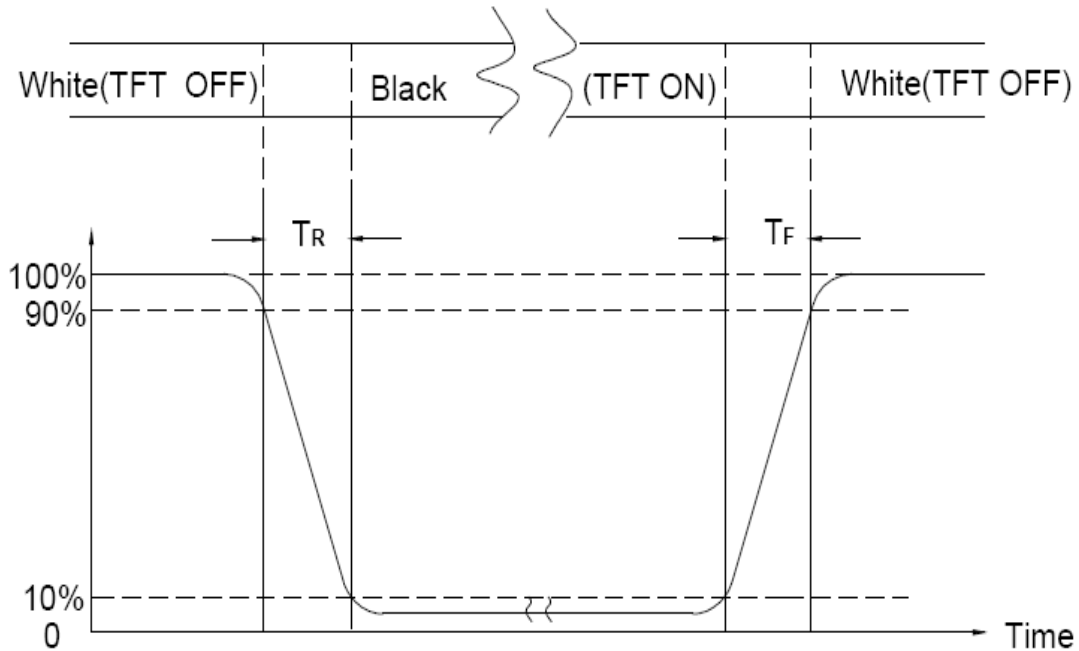



## 8. Interface Pin Assignment:

### 8-1 LCM FPC Interface

No.	Symbol	Function
1	GND	Power Ground.
2	LED- (K)	Cathode of LED Backlight.
3	LED+ (A)	Anode of LED Backlight.
4	VDDA	Power Supply for Analog.
5	VDDI	Power supply for I/O system.
6	TE	Tearing effect output. If not used, leave this pin open.
7	CSX	Chip select signal.
8	DCX(RS)	Display data/command selection (RS) pin in MCU interface. DCX=1: display data or parameter. DCX=0: register index / command.
9	WRX/SCL	Write enable in MCU parallel interface. In SPI mode, this pin is used as SCL.
10	RDX	Read enable in 8080 MCU parallel interface. Low-active.
11	SDA	SPI interface input/output pin. The data is latched on the rising edge of the SCL signal. If not used, please fix this pin at VDDI or GND level.
12	DOUT/SDO	SPI interface output pin. The data is outputted on the falling edge of the SCL signal. If not used, please fix this pin at floating.
13	DB0	Data Bus.
14	DB1	
15	DB2	
16	DB3	
17	DB4	
18	DB5	
19	DB6	
20	DB7	
21	DB8	
22	DB9	



No.	Symbol	Function
23	DB10	Data Bus.
24	DB11	
25	DB12	
26	DB13	
27	DB14	
28	DB15	
29	DB16	
30	DB17	
31	ENABLE	Data enable signal for RGB interface operation. If not used, please fix this pin at VDDI or GND.
32	DOTCLK	Dot clock signal for RGB interface operation. If not used, please fix this pin at VDDI or GND.
33	HSYNC	Horizontal synchronizing input signal for RGB interface operation. If not used, please fix this pin at VDDI or GND.
34	VSYNC	Vertical synchronizing input signal for RGB interface operation. If not used, please fix this pin at VDDI or GND.
35	RESET	Reset pin.
36	IM2	The interface mode select. Note1
37	IM1	
38	IM0	
39	GND	Power Ground.
40	NC(YU)	Open.
41	NC(XL)	Open.
42	NC(YD)	Open.
43	NC(XR)	Open.

Note 1:

IM2	IM1	IM0	MPU Interface Mode	Data pin
0	0	0	8080 18-bit Interface	DB[17:0]
0	0	1	8080 9-bit Interface	DB[8:0]
0	1	0	8080 16-bit Interface	DB[15:0]
0	1	1	8080 8-bit Interface	DB[7:0],
1	0	0	Reserve	--
1	0	1	3SPI	SDA, SDO
1	1	0	Reserve	--
1	1	1	4Line SPI	SDA, SDO

## 8-2 CTP Interface Pin

No.	Symbol	Function
1	VDD	Analog power supply.
2	RESET	RESET.
3	INT	External interrupt pin to host.
4	SCL	Serial clock pin for I2C interface.
5	SDA	Serial data pin for I2C interface.
6	GND	Ground.

**9. Block Diagram:**

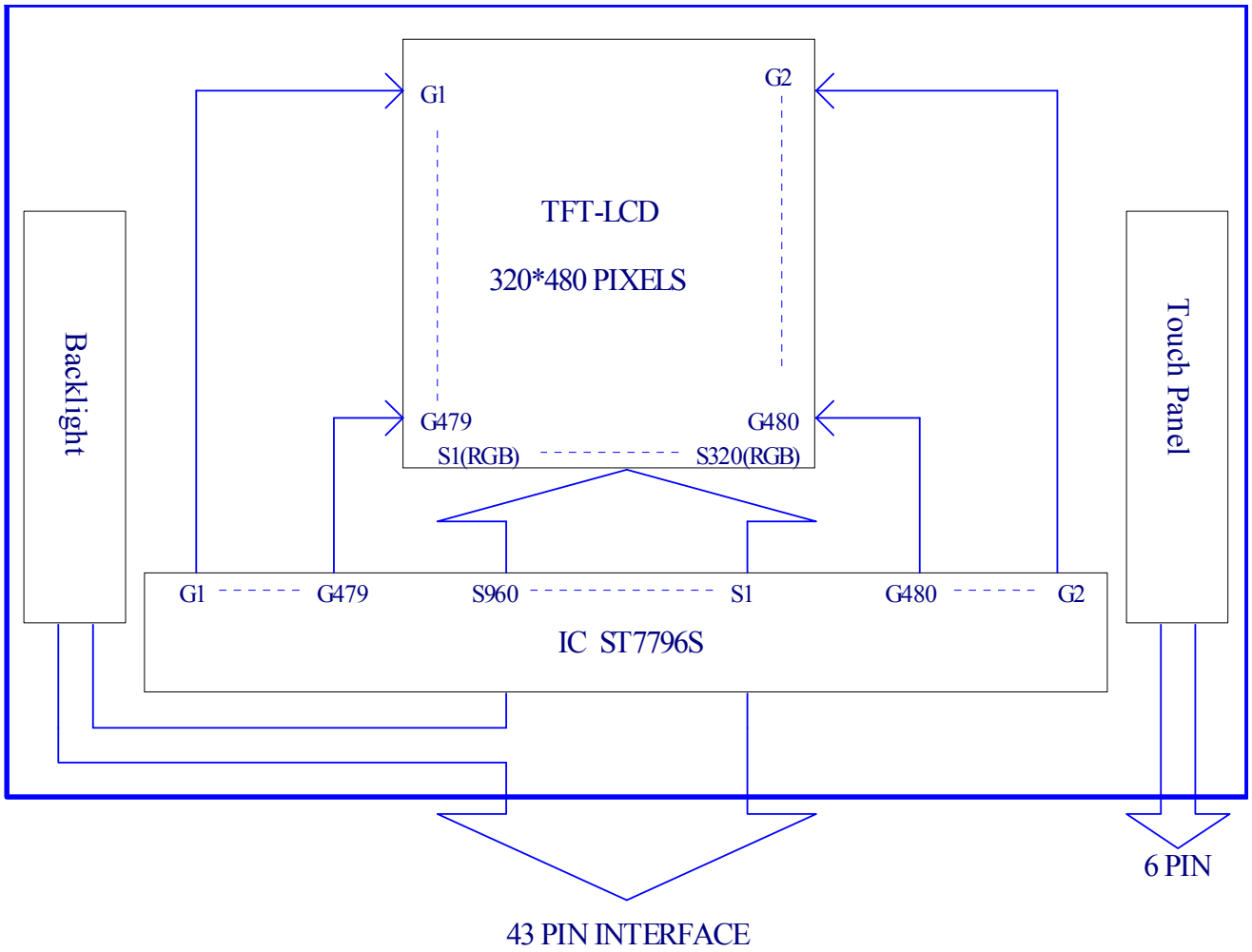

## 10. Backlight:

### 1. Standard Lamp Styles (Edge Lighting Type):

The LED chips are distributed over the edge light area of the illumination unit, which gives the less power consumption:

### 2. The Main Advantages of the LED Backlight are as following:

- 2.1 The brightness of the backlight can simply be adjusted.  
By a resistor or a potentiometer.

### 3. Data About LED Backlight:

(Ta=25°C)

PARAMETER	Sym.	Min.	Typ.	Max.	Unit	Test Condition	Note
Supply Current	I	-	20	-	mA	V=19.8V	
Supply Voltage	V	18.0	19.8	20.4	V	If=20mA	
Luminous Intensity for LCM	IV	220	300	-	cd/m <sup>2</sup>		2
Uniformity for LCM	-	70	-	-	%		3
Life Time	-	20000	50000	-	Hr.		4
Color	White						

NOTE:

- Backlight Only
- Average Luminous Intensity of P1-P9
- Uniformity = Min/Max \* 100%
- LED life time defined as follows: The final brightness is at 50% of original brightness

### Measured Method: (X\*Y: Light Area)

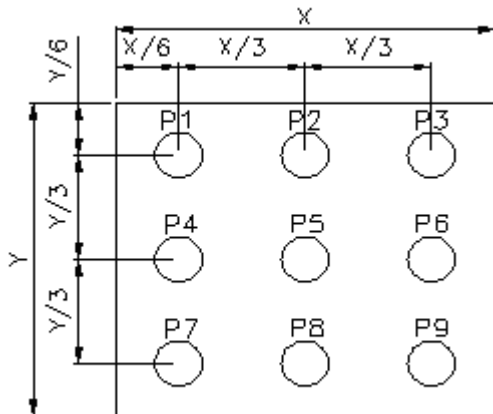

### Internal Circuit Diagram



### (Effective spatial Distribution)

Hole Diameter  $\varnothing 3$  mm; 1 to 9 per Position Measured Luminous

## 11. Standard Specification for Reliability:

### 11-1. Standard Specifications for Reliability of LCD Module

No	Item	Description
01	High temperature operation	The sample should be allowed to stand at 70°C for 120 hours under driving condition and then returning it to normal temperature condition, and allowing it stand for 2 hours.
02	Low temperature operation	The sample should be allowed to stand at -20°C for 120 hours under driving condition and then returning it to normal temperature condition, and allowing it stand for 2 hours.
03	High temperature storage	The sample should be allowed to stand at 80°C for 240 hours under no-load condition, and then returning it to normal temperature condition, and allowing it stand for 2 hours.
04	Low temperature storage	The sample should be allowed to stand at -30°C for 240 hours under no-load condition, then returning it to normal temperature condition, and allowing it stand for 2 hours.
05	Moisture storage	The sample should be allowed to stand at 60°C,90%RH MAX for 240 hours under no-load condition, then taking it out and drying it at normal temperature for 2 hours.
06	Thermal shock storage	The sample should be allowed to stand the following 10 cycles : -30°C for 30 minutes → normal temperature for 5 minutes → +80°C for 30 minutes → normal temperature for 5 minutes, as one cycle.
07	Packing vibration	Frequency range : 10Hz ~ 55Hz Amplitude of vibration : 1.5mm      Sweep time: 12 min X,Y,Z 2 hours for each direction.
08	Packing drop test	According to ISTA 1A 2001.
09	Electrical Static Discharge	Air: ±4KV 150pF/330Ω 5 times
		Contact: ±2KV 150pF/330Ω 5 time

\*Sample size for each test item is 3~5pcs

## 11 - 2. Testing Conditions and Inspection Criteria

For the final test the testing sample must be stored at room temperature for 24 hours, after the tests listed in Table 11.2, Standard specifications for Reliability have been executed in order to ensure stability.

No	Item	Test Model	In section Criteria
01	Current Consumption	Refer To Specification	The current consumption should conform to the product specification.
02	Contrast	Refer To Specification	After the tests have been executed, the contrast must be larger than half of its initial value prior to the tests.
03	Appearance	Visual inspection	Defect free.

## 11- 3. MTBF

MTBF	Functions, performance, appearance, etc. shall be free from remarkable deterioration within 50,000 hours under ordinary operating and storage conditions room temperature ( $25\pm 5^{\circ}\text{C}$ ), normal humidity ( $50\pm 10\%$ RH), and in area not exposed to direct sun light.
------	---

## 12. Specification of Quality Assurance:

### 12-1. Purpose

This standard for Quality Assurance should affirm the quality of LCD module products to supply to purchaser by YEEBO CORPORATION (Supplier).

### 12-2. Standard for Quality Test

#### a. Inspection:

Before delivering, the supplier should take the following tests, and affirm the quality of product.

#### b. Electro-Optical Characteristics:

According to the individual specification to test the product.

#### c. Test of Appearance Characteristics:

According to the individual specification to test the product.

#### d. Test of Reliability Characteristics:

According to the definition of reliability on the specification for testing products.

#### e. Delivery Test:

Before delivering, the supplier should take the delivery test.

(i) Test method: According to **ISO2859-1**. General Inspection Level II take a single time.

(ii) The defects classify of AQL as following:

Major defect: AQL = 0.65

Minor defect: AQL = 2.5

Total defects: AQL = 2.5

### 12-3. Non- conforming Analysis & Deal With Manners

#### a. Non- conforming Analysis:

(i) Purchaser should supply the detail data of non- conforming sample and the non- conforming.

(ii) After accepting the detail data from purchaser, the analysis of non- conforming should be finished in two weeks.

(iii) If supplier can not finish analysis on time, must announce purchaser before 3 days.

#### b. Disposition of non- conforming:

(i) If find any product defect of supplier during assembly time, supplier must change the good product for every defect after recognition.

(ii) Both supplier and customer should analyze the reason and discuss the disposition of non- conforming when the reason of nonconforming is not sure.

### 12-4. Agreement items

Both sides should discuss together when the following problems happen.

a. There is any problem of standard of quality assurance, and both sides should think that must be modified.

b. There is any argument item which does not record in the standard of quality assurance.

c. Any other special problem.

12-5. Standard of The Product Appearance Test

a. Manner of appearance test:

(i) The test must be under 20W × 2 or 40W fluorescent light, and the distance of view must be at 30±5cm.

(ii) When test the model of transmissive product must add the reflective plate.

(iii) The test direction is base on around 10° of vertical line.

(iiii) Temperature: 25±5°C Humidity: 60±10%RH

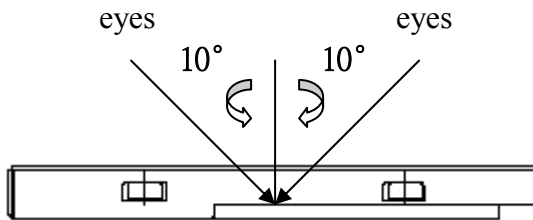

(iv) Definition of area:

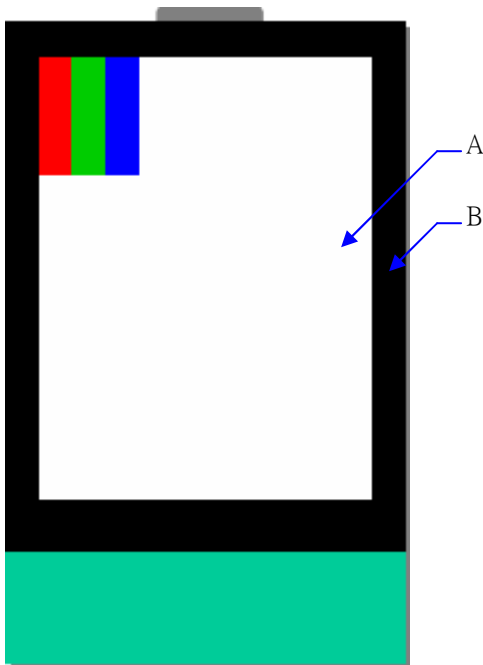

A. Area: Viewing area.

B. Area: Out of viewing area.  
(Outside viewing area)

b. Basic principle:

(i) It will accord to the AQL when the standard can not be described.

(ii) The sample of the lowest acceptable quality level must be discussed by both supplier and customer when any dispute happened.

(iii) Must add new item on time when it is necessary.

c. Standard of inspection: (Unit: mm)



**12-6. Inspection specification**

Defect out of viewing area can be neglected.

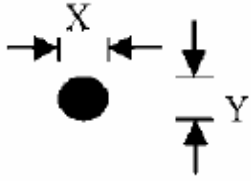
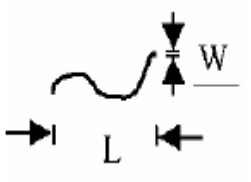
NO	Item	Criterion	AQL												
01	Electrical Testing	1.1 Missing vertical, horizontal segment, segment contrast defect. 1.2 Missing character, dot or icon. 1.3 Display malfunction. 1.4 No function or no display. 1.5 Current consumption exceeds product specifications. 1.6 LCD viewing angle defect. 1.7 Mixed product types. 1.8 Flicker	<b>0.65</b>												
02	Black or White spots or Bright spots or Color spots on LCD (Display only)	2.1 White and black or color spots on display $\leq 0.25\text{mm}$ , no more than Five spots. 2.2 Densely spaced: No more than three spots within 3mm. 2.3 Not visible through 5% ND filter	<b>2.5</b>												
03	LCD and Touch Panel black spots, white spots, contamination (non – display)	3.1 Round type: As following drawing $\Phi = (X+Y) / 2$  <table border="1" data-bbox="758 1041 1292 1288"> <thead> <tr> <th>Size(mm)</th> <th>Acceptable Q'ty</th> </tr> </thead> <tbody> <tr> <td><math>\Phi \leq 0.10</math></td> <td>Accept no dense</td> </tr> <tr> <td><math>0.10 &lt; \Phi \leq 0.20</math></td> <td>2</td> </tr> <tr> <td><math>0.20 &lt; \Phi \leq 0.25</math></td> <td>2</td> </tr> <tr> <td><math>0.25 &lt; \Phi \leq 0.30</math></td> <td>1</td> </tr> <tr> <td><math>0.30 &lt; \Phi</math></td> <td>0</td> </tr> </tbody> </table> <p>* Densely spaced: No more than two spots within 3mm.</p>	Size(mm)	Acceptable Q'ty	$\Phi \leq 0.10$	Accept no dense	$0.10 < \Phi \leq 0.20$	2	$0.20 < \Phi \leq 0.25$	2	$0.25 < \Phi \leq 0.30$	1	$0.30 < \Phi$	0	<b>2.5</b>
		Size(mm)	Acceptable Q'ty												
$\Phi \leq 0.10$	Accept no dense														
$0.10 < \Phi \leq 0.20$	2														
$0.20 < \Phi \leq 0.25$	2														
$0.25 < \Phi \leq 0.30$	1														
$0.30 < \Phi$	0														
3.2 Line type: (As following drawing)  <table border="1" data-bbox="662 1444 1292 1713"> <thead> <tr> <th>Length(mm)</th> <th>Width(mm)</th> <th>Acceptable Q'ty</th> </tr> </thead> <tbody> <tr> <td>---</td> <td><math>W \leq 0.02</math></td> <td>Accept no dense</td> </tr> <tr> <td><math>L \leq 3.0</math></td> <td><math>0.02 &lt; W \leq 0.05</math></td> <td rowspan="2">2</td> </tr> <tr> <td><math>L \leq 2.5</math></td> <td><math>0.03 &lt; W \leq 0.08</math></td> </tr> <tr> <td>---</td> <td><math>0.08 &lt; W</math></td> <td>Rejection</td> </tr> </tbody> </table> <p>* Densely spaced: No more than two lines within 3mm.</p>	Length(mm)	Width(mm)	Acceptable Q'ty	---	$W \leq 0.02$	Accept no dense	$L \leq 3.0$	$0.02 < W \leq 0.05$	2	$L \leq 2.5$	$0.03 < W \leq 0.08$	---	$0.08 < W$	Rejection	<b>2.5</b>
Length(mm)	Width(mm)	Acceptable Q'ty													
---	$W \leq 0.02$	Accept no dense													
$L \leq 3.0$	$0.02 < W \leq 0.05$	2													
$L \leq 2.5$	$0.03 < W \leq 0.08$														
---	$0.08 < W$	Rejection													

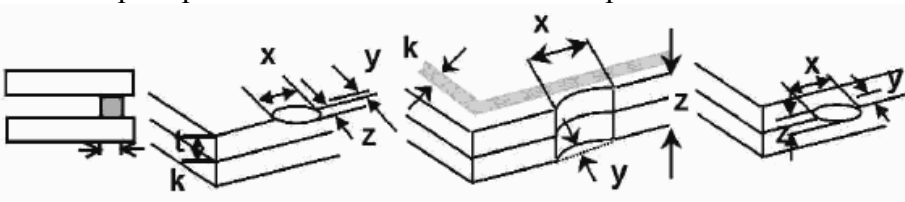
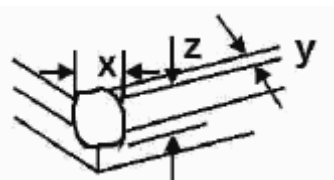
NO	Item	Criterion	AQL																		
04	Polarizer bubbles	<p>If bubbles are visible, judge using black spot specifications, not easy to find, must check in specify direction</p> <table border="1"> <thead> <tr> <th>Size <math>\Phi</math>(mm)</th> <th>Acceptable Q'ty</th> </tr> </thead> <tbody> <tr> <td><math>\Phi \leq 0.20</math></td> <td>Accept no dense</td> </tr> <tr> <td><math>0.20 &lt; \Phi \leq 0.50</math></td> <td>3</td> </tr> <tr> <td><math>0.50 &lt; \Phi \leq 1.00</math></td> <td>2</td> </tr> <tr> <td><math>1.00 &lt; \Phi</math></td> <td>0</td> </tr> <tr> <td>Total Q'ty</td> <td>3</td> </tr> </tbody> </table>	Size $\Phi$ (mm)	Acceptable Q'ty	$\Phi \leq 0.20$	Accept no dense	$0.20 < \Phi \leq 0.50$	3	$0.50 < \Phi \leq 1.00$	2	$1.00 < \Phi$	0	Total Q'ty	3	2.5						
Size $\Phi$ (mm)	Acceptable Q'ty																				
$\Phi \leq 0.20$	Accept no dense																				
$0.20 < \Phi \leq 0.50$	3																				
$0.50 < \Phi \leq 1.00$	2																				
$1.00 < \Phi$	0																				
Total Q'ty	3																				
05	Scratches	Follow NO.3 -2 Line Type.																			
06	Mura	Not visible through 5% ND filter in 50% gray.	2.5																		
07	Chipped glass	<p>Symbols:            x: Chip length      y: Chip width      z: Chip thickness            k: Seal width      t: Glass thickness      a: LCD side length            L: Electrode pad length</p> <p>7.1 General glass chip:            7.1.1 Chip on panel surface and crack between panels:</p>  <table border="1"> <thead> <tr> <th>z: Chip thickness</th> <th>y: Chip width</th> <th>x: Chip length</th> </tr> </thead> <tbody> <tr> <td><math>Z \leq 1/2t</math></td> <td>Not over viewing area</td> <td><math>x \leq 1/8a</math></td> </tr> <tr> <td><math>1/2t &lt; z \leq 2t</math></td> <td>Not exceed 1/3k</td> <td><math>x \leq 1/8a</math></td> </tr> </tbody> </table> <p>⊙ Unit: mm            ⊙ If there are 2 or more chips, x is the total length of each chip</p> <p>7.1.2 Corner crack:</p>  <table border="1"> <thead> <tr> <th>z: Chip thickness</th> <th>y: Chip width</th> <th>x: Chip length</th> </tr> </thead> <tbody> <tr> <td><math>Z \leq 1/2t</math></td> <td>Not over viewing area</td> <td><math>x \leq 1/8a</math></td> </tr> <tr> <td><math>1/2t &lt; z \leq 2t</math></td> <td>Not exceed 1/3k</td> <td><math>x \leq 1/8a</math></td> </tr> </tbody> </table> <p>⊙ Unit: mm            ⊙ If there are 2 or more chips, x is the total length of each chip</p>	z: Chip thickness	y: Chip width	x: Chip length	$Z \leq 1/2t$	Not over viewing area	$x \leq 1/8a$	$1/2t < z \leq 2t$	Not exceed 1/3k	$x \leq 1/8a$	z: Chip thickness	y: Chip width	x: Chip length	$Z \leq 1/2t$	Not over viewing area	$x \leq 1/8a$	$1/2t < z \leq 2t$	Not exceed 1/3k	$x \leq 1/8a$	2.5
z: Chip thickness	y: Chip width	x: Chip length																			
$Z \leq 1/2t$	Not over viewing area	$x \leq 1/8a$																			
$1/2t < z \leq 2t$	Not exceed 1/3k	$x \leq 1/8a$																			
z: Chip thickness	y: Chip width	x: Chip length																			
$Z \leq 1/2t$	Not over viewing area	$x \leq 1/8a$																			
$1/2t < z \leq 2t$	Not exceed 1/3k	$x \leq 1/8a$																			

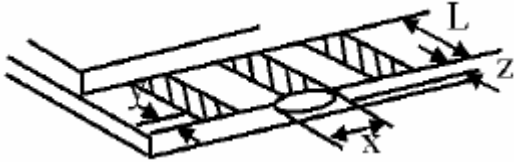
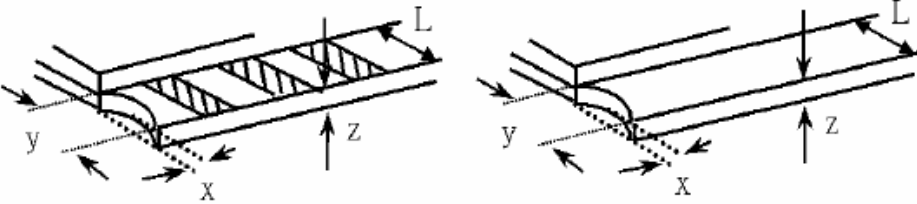
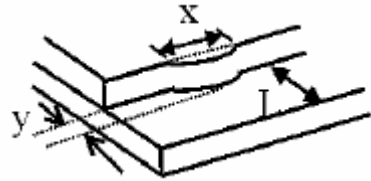
NO	Item	Criterion	AQL																
08	Glass crack	<p>Symbols:            x: Chip length      y: Chip width      z: Chip thickness            k: Seal width      t: Glass thickness      a: LCD side length            L: Electrode pad length</p> <p>8.1 Protrusion over terminal:            8.1.1 Chip on electrode pad:</p>  <table border="1" data-bbox="486 696 1171 853"> <tr> <td>y: Chip width</td> <td>x: Chip length</td> <td>z: Chip thickness</td> </tr> <tr> <td><math>y \leq 0.5\text{mm}</math></td> <td><math>x \leq 1/8a</math></td> <td><math>0 &lt; z \leq t</math></td> </tr> </table> <p>8.1.2            Non-conductive portion:</p>  <table border="1" data-bbox="486 1211 1171 1368"> <tr> <td>y: Chip width</td> <td>x: Chip length</td> <td>z: Chip thickness</td> </tr> <tr> <td><math>y \leq L</math></td> <td><math>x \leq 1/8a</math></td> <td><math>0 &lt; z \leq t</math></td> </tr> </table> <p>⊙ If there chipped area touches the ITO terminal, over 2/3 of the ITO must remain and be inspected according to electrode terminal specifications.            ⊙ If the product will be heat sealed by the customer, the alignment mark must not be damaged.</p> <p>8.1.3 Substrate protuberance and internal crack</p>  <table border="1" data-bbox="805 1682 1246 1839"> <tr> <td>y: width</td> <td>x: length</td> </tr> <tr> <td><math>y \leq 1/3L</math></td> <td><math>X \leq a</math></td> </tr> </table>	y: Chip width	x: Chip length	z: Chip thickness	$y \leq 0.5\text{mm}$	$x \leq 1/8a$	$0 < z \leq t$	y: Chip width	x: Chip length	z: Chip thickness	$y \leq L$	$x \leq 1/8a$	$0 < z \leq t$	y: width	x: length	$y \leq 1/3L$	$X \leq a$	2.5
y: Chip width	x: Chip length	z: Chip thickness																	
$y \leq 0.5\text{mm}$	$x \leq 1/8a$	$0 < z \leq t$																	
y: Chip width	x: Chip length	z: Chip thickness																	
$y \leq L$	$x \leq 1/8a$	$0 < z \leq t$																	
y: width	x: length																		
$y \leq 1/3L$	$X \leq a$																		

NO	Item	Criterion	AQL
09	Cracked glass	The LCD with extensive crack is not acceptable.	2.5
10	Backlight elements	10.1 Illumination source flickers when lit. 10.2 Spots or scratches that appear when lit must be judged. Using LCD spot, lines and contamination standards. 10.3 Backlight doesn't light or color is wrong.	2.5 2.5 0.65
11	Bezel	Bezel must comply with product specifications.	2.5
12	PCB、COB	12.1 COB seal may not have pinholes larger than 0.2mm or contamination. 12.2 COB seal surface may not have pinholes through to the IC. 12.3 The height of the COB should not exceed the height indicated in the assembly diagram. 12.4 There may not be more than 2mm of sealant outside the seal area on PCB. And there should be no more than three places. 12.5 Parts on PCB must be the same as on the production characteristic chart, There should be no wrong parts, missing parts or excess parts. 12.6 The jumper on the PCB should conform to the product characteristic chart.	2.5 2.5 2.5 2.5 0.65 0.65
13	FPC	13.1 FPC terminal damage $\leq$ 1/2 FPC terminal width and can not affect the function , we judge accept. 13.2 FPC alignment hole damage $\leq$ 1/2 alignment area and can not affect the function , we judge accept.	2.5 2.5
14	Soldering	14.1 No cold solder joints, missing solder connections, oxidation or icide. 14.2 No short circuits in components on PCB or FPC.	2.5 0.65

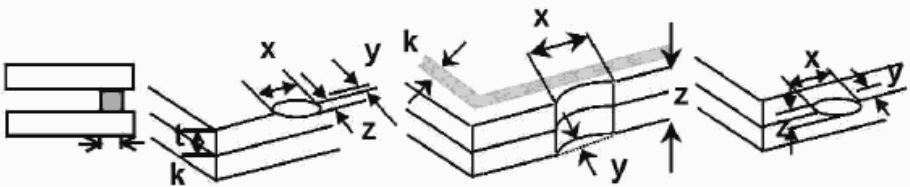
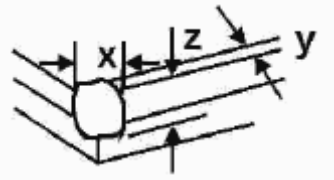
NO	Item	Criterion	AQL												
15	Touch Panel Chipped glass	<p>Symbols:            x: Chip length                      y: Chip width                      z: Chip thickness            k: Seal width                      t: Touch Panel Total thickness    a: LCD side length            L: Electrode pad length</p> <p>15.1 General glass chip:            15.1.1 Chip on panel surface and crack between panels:</p>  <table border="1" data-bbox="343 813 1161 1030"> <tr> <td>z: Chip thickness</td> <td>y: Chip width</td> <td>x: Chip length</td> </tr> <tr> <td><math>Z \leq t</math></td> <td><math>\leq 1/2 k</math> and not over viewing area</td> <td><math>x \leq 1/8a</math></td> </tr> </table> <p>⊙ Unit: mm            ⊙ If there are 2 or more chips, x is the total length of each chip</p> <p>15.1.2 Corner crack:</p>  <table border="1" data-bbox="343 1408 1161 1626"> <tr> <td>z: Chip thickness</td> <td>y: Chip width</td> <td>x: Chip length</td> </tr> <tr> <td><math>z \leq t</math></td> <td><math>\leq 1/2 k</math> and not over viewing area</td> <td><math>x \leq 1/8a</math></td> </tr> </table> <p>⊙ Unit: mm            ⊙ If there are 2 or more chips, x is the total length of each chip</p>	z: Chip thickness	y: Chip width	x: Chip length	$Z \leq t$	$\leq 1/2 k$ and not over viewing area	$x \leq 1/8a$	z: Chip thickness	y: Chip width	x: Chip length	$z \leq t$	$\leq 1/2 k$ and not over viewing area	$x \leq 1/8a$	2.5
z: Chip thickness	y: Chip width	x: Chip length													
$Z \leq t$	$\leq 1/2 k$ and not over viewing area	$x \leq 1/8a$													
z: Chip thickness	y: Chip width	x: Chip length													
$z \leq t$	$\leq 1/2 k$ and not over viewing area	$x \leq 1/8a$													

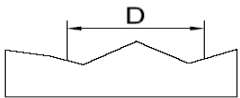
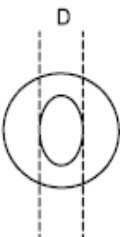
NO	Item	Criterion	AQL										
16	Touch Panel(Fish eye、dent and bubble on film)	<table border="1"> <thead> <tr> <th>SIZE(mm)</th> <th>Acceptable Q'ty</th> </tr> </thead> <tbody> <tr> <td><math>\Phi \leq 0.2</math></td> <td>Accept no dense</td> </tr> <tr> <td><math>0.2 &lt; D \leq 0.4</math></td> <td>5</td> </tr> <tr> <td><math>0.4 &lt; D \leq 0.5</math></td> <td>2</td> </tr> <tr> <td><math>0.5 &lt; D</math></td> <td>0</td> </tr> </tbody> </table>	SIZE(mm)	Acceptable Q'ty	$\Phi \leq 0.2$	Accept no dense	$0.2 < D \leq 0.4$	5	$0.4 < D \leq 0.5$	2	$0.5 < D$	0	2.5
		SIZE(mm)	Acceptable Q'ty										
		$\Phi \leq 0.2$	Accept no dense										
		$0.2 < D \leq 0.4$	5										
		$0.4 < D \leq 0.5$	2										
$0.5 < D$	0												
													
													
17	Touch Panel Newton ring	Newton ring dimension $\leq 1/2$ touch panel area and not affect font and line distortion( $\leq 2.5\%$ ) , it is acceptable.	2.5										
18	Touch Panel Linearity	Less than 2.5% is acceptable.	2.5										
19	LCD Ripple	Touch the touch panel , can not see the LCD ripple. Pen: R 1.0mm silicon rubber. Operation Force: 80g	2.5										
20	General appearance	20.1 Pin type must match type in specification sheet.	0.65										
		20.2 LCD pin loose or missing pins.	0.65										
		20.3 Product packaging must the same as specified on packaging specification sheet.	0.65										
		20.4 Product dimension and structure must conform to product specification sheet.	0.65										

## **13. Handling Precaution:**

### 13-1 Handling of LCM

- Don't give external shock.
- Don't apply excessive force on the surface.
- Liquid in LCD is hazardous substance. Must not lick and swallow. when the liquid is attach to your hand, skin, cloth etc. Wash it out thoroughly and immediately.
- Don't operate it above the absolute maximum rating.
- Don't disassemble the LCM.
- The operators should be grounded whenever he/she comes into contact with the module. Never touch any of the conductive parts such as the LSI pads, the copper leads on the PCB and the interface terminals with any parts of the human body.
- The modules should be kept in antistatic bags or other containers resistant to static for storage.
- The module is coated with a film to protect the display surface. Be care when peeling off this protective film since static electricity may be generated.

### 13-2 Storage

- Store in an ambient temperature of  $25\pm 10^{\circ}\text{C}$ , and in a relative humidity of  $50\pm 10\%\text{RH}$ . Don't expose to sunlight or fluorescent light.
- Storage in a clean environment, free from dust, active gas, and solvent.
- Store in anti-static electricity container.
- Store without any physical load.

### 13-3 Soldering

- Use only soldering irons with proper grounding and no leakage.
- Iron: No higher than  $280\pm 10^{\circ}\text{C}$  and less than 3 sec during Hand soldering.
- Rewiring: no more than 2 times.

## **14. Guarantee:**

Our products could meet requirements of the environment.

YB's RoHS is introduce European Union Directive 2011/65/EU (ROHS) Requirements and Update.